



Characterization of a Standard Single-Mode Fiber Link for NRZ Modulated Optical Signal at 40 Gbps

Master's Project Defense

by

Ashvini Canjeevaram Ganesh

Advisor: Dr. Chris Allen

Dr. Ronqing Hui

Dr. Victor Frost

Department of Electrical Engineering and Computer Science

University of Kansas

January 23, 2004

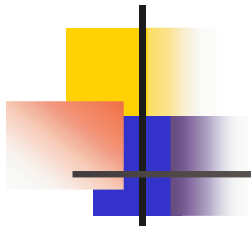

- Motivation and Challenges
- Generation of 40 Gbps Optical Signal
- Effects of Chromatic Dispersion and Polarization Mode Dispersion at 40 Gbps
- Experiments, Inferences and Field Trial
- Conclusions and Suggestions for Future Work



Motivation

- Explosive expansion of the internet has led to an ever-increasing demand for bandwidth
- To meet this demand, we can either increase the number of wavelengths at 10 Gbps or increase the bit rate to 40 Gbps
- Design rules say that 10 Gbps channels can sit on 25 GHz channel spacing and 40 Gbps channels can sit on 100 GHz channel spacing
- Wider channel spacing reduces the effects due to nonlinearities
- Higher per channel rate reduces operational expenses
- However, certain issues need to be addressed to operate at 40 Gbps

Challenges at 40 Gbps



Optical Signal-to-Noise Ratio (OSNR)

- A system operating at 40 Gbps per channel requires an OSNR of 6 dB higher than that required for 10 Gbps systems to achieve the same BER
- EDFAs introduce amplified spontaneous emission noise (ASE), which degrades the OSNR of the link.
- To maintain a good OSNR, we have to boost the signal periodically and balance the gain against the ASE noise which the amplifier introduces
- Thus, EDFAs have to be placed at shorter distances when operating at 40 Gbps



Challenges at 40 Gbps

Chromatic Dispersion

- Pulse broadening occurs as different spectral components travel with different velocities along the length of the fiber
- The dispersion 'D' that can be tolerated is inversely proportional to the square of the bit-rate 'R', given by

$$D.L \text{ (ps/nm)} = 10^5/R^2$$

- At 10 Gbps, we can tolerate a dispersion of 1000 ps/nm and at 40 Gbps, we can tolerate up to 62.5 ps/nm.
- Thus, 40 Gbps systems are 16 times more sensitive to chromatic dispersion and dispersion compensation has to be employed even for smaller span lengths to send information at high bit rates



Challenges at 40 Gbps

Polarization Mode Dispersion (PMD)

- Birefringence in single mode fibers causes PMD
- PMD is a random process, it changes with wavelength, temperature, movement of the fiber and other environmental factors
- With fibers deployed with say PMD coefficient = $0.5 \text{ ps}/(\text{km})^{1/2}$, the maximum optical transmission distance without a PMD compensator is around 14 km at 40 Gbps as compared to 230 km at 10 Gbps
- Hence, PMD is a more serious limitation of long distance transport in 40 Gbps systems than 10 Gbps systems and PMD compensation is a must



Generation of 40 Gbps Optical Signal

- The bit error rate tester (BERT) in the laboratory sends and receives data at 10 Gb/s
- Components required to upgrade the 10 Gb/s pattern generator to 40 Gb/s are: SHF 10410 1:4 signal splitter, SHF 4005A 44 Gbps 4:1 multiplexer and SHF 1020B frequency doubler
- The 1:4 signal splitter receives the 10 Gbps signal from the BERT as input and outputs four 10 Gbps signals
- The 4:1 multiplexer generates a data stream of 40 Gbps using the four 10 Gbps data signals from the splitter
- The frequency doubler is used to provide 20 GHz clock signal to the multiplexer from the 10 GHz clock source available from the BERT

Generation of 40 Gbps Optical Signal

- The following figure shows the set-up to generate 40 Gbps optical signal from 10 Gbps BERT

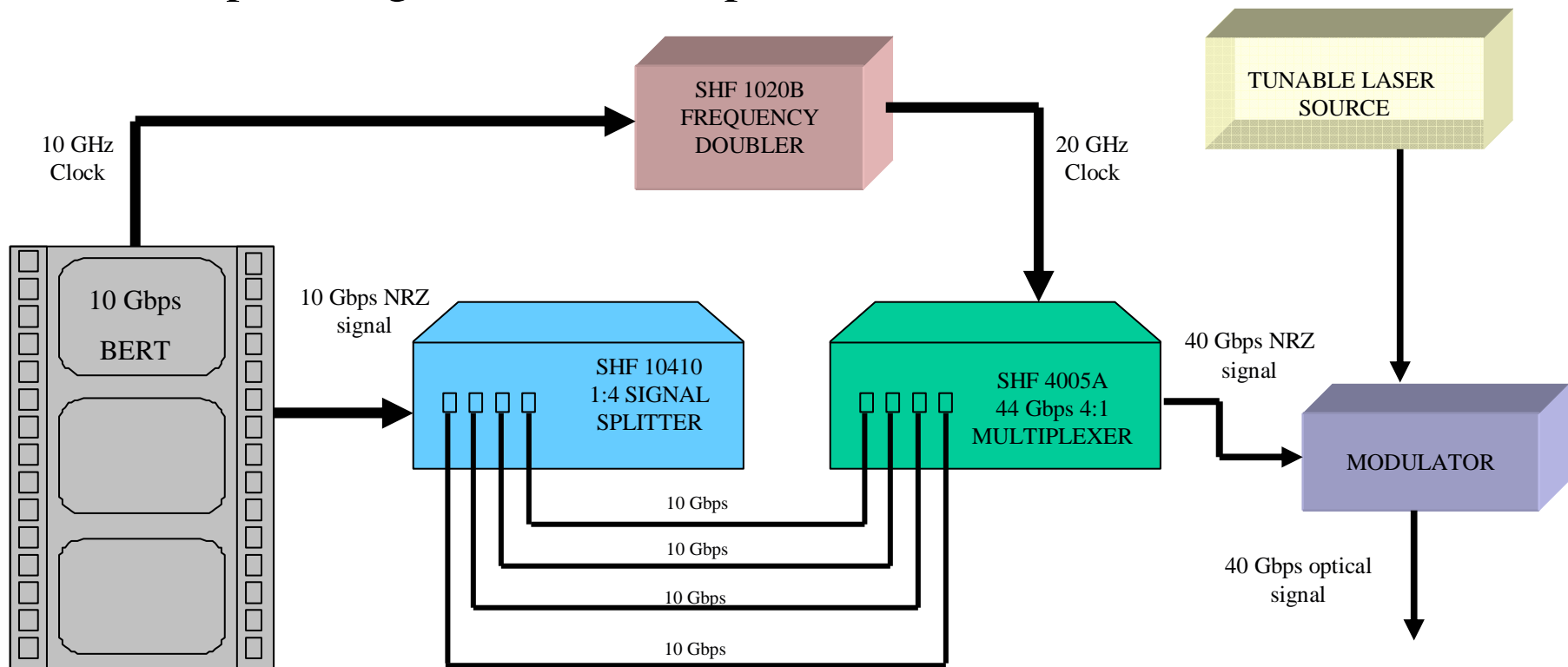

Generation of 40 Gbps optical signal from 10 Gbps BERT

Effects of Chromatic Dispersion at 40 Gbps

- At 40 Gbps, we can tolerate a dispersion of only 62.5 ps/nm
- The transmission quality begins to degrade after just 4 km of standard single-mode fiber (SSMF)
- Figures a-d illustrate how the signal quality degrades after 0 km, 2 km, 5 km and 8 km of spooled SSMF

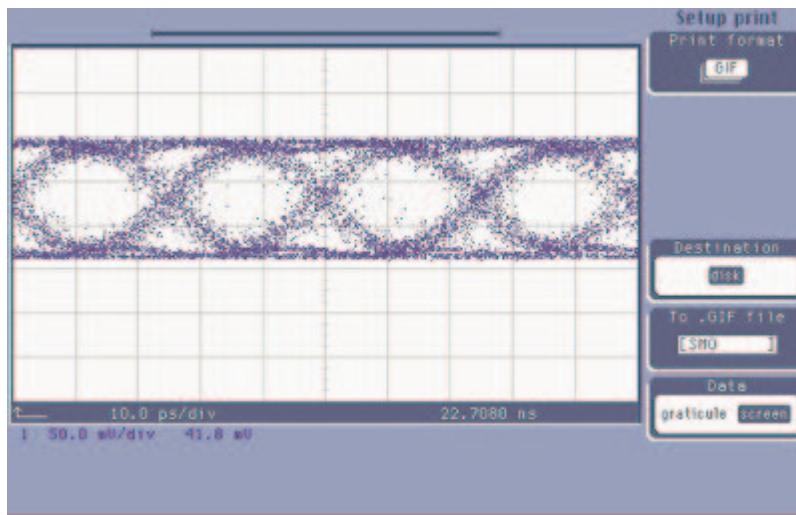

Figure (a) Eye-Diagram when connected back-to-back at 40 Gbps

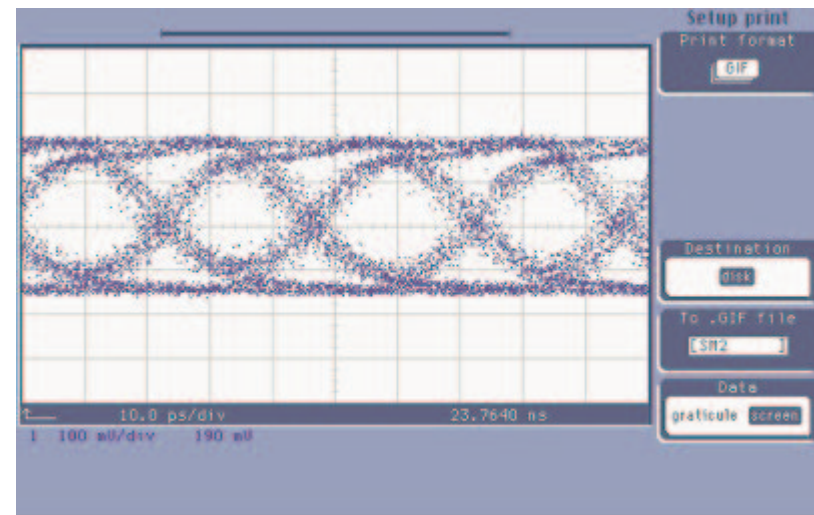

Figure (b) Eye-Diagram at 40 Gbps after 2 km transmission of SSMF

Effects of Chromatic Dispersion at 40 Gbps

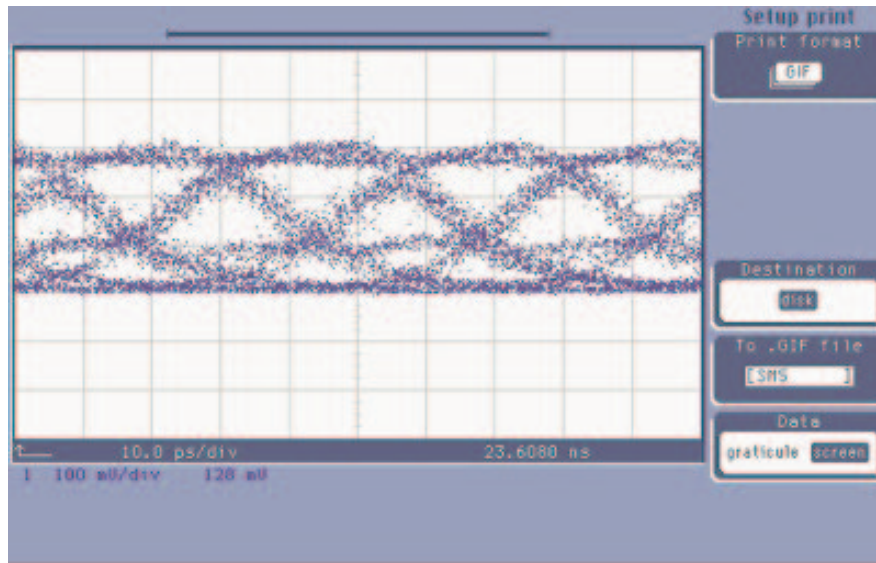

Figure (c) Eye-Diagram at 40 Gbps after 5 km transmission of SSMF

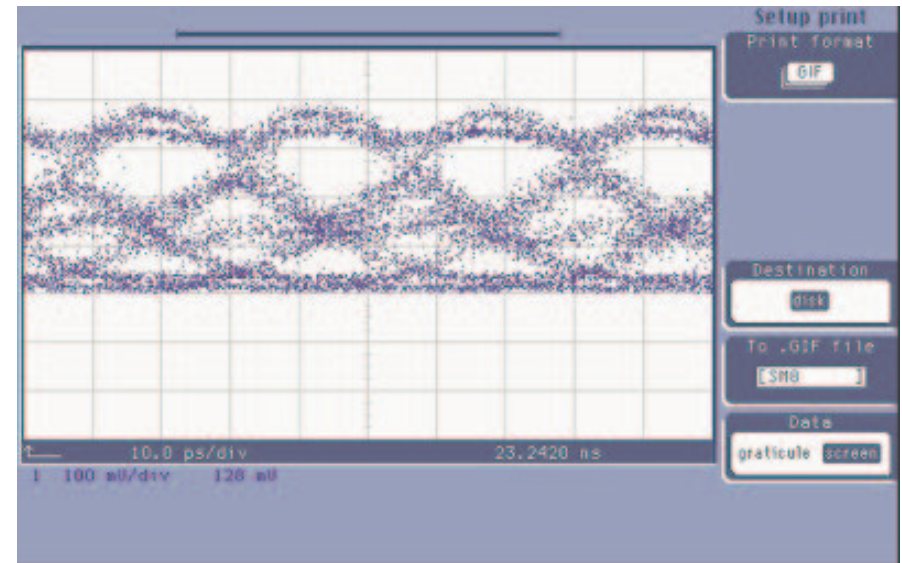
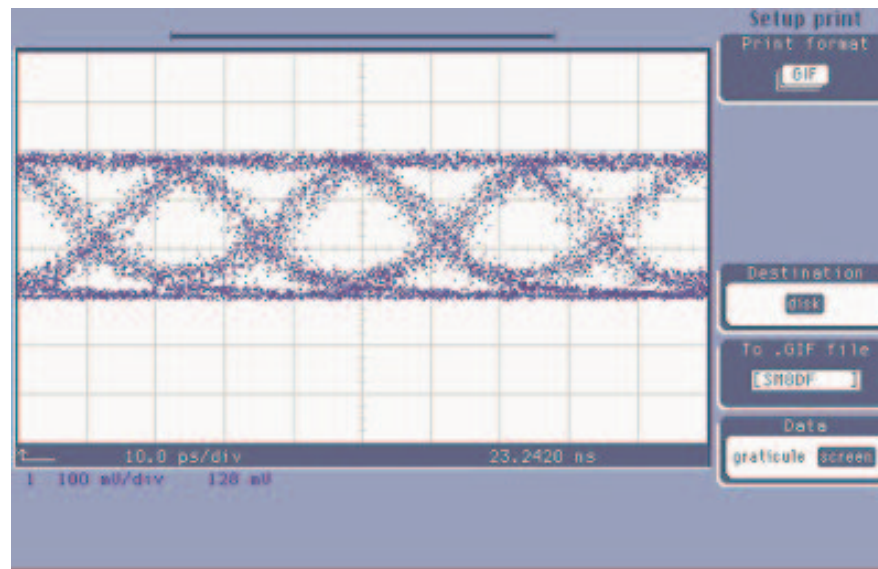

Figure (d) Eye-Diagram at 40 Gbps after 8 km transmission of SSMF

- Figure (c) shows that after 5 km of SSMF spool, the signal is quite distorted by chromatic dispersion and there is a need for compensation. The dispersion is approximately 85 ps/nm and we can tolerate only 62.5 ps/nm

Effects of Chromatic Dispersion at 40 Gbps

- To compensate for chromatic dispersion on the 8 km spool of fiber, we used DCF 10 module and the eye pattern after compensation is shown below



Eye-Diagram at 40 Gbps after 8 km transmission of SSMF and dispersion compensation

- Hence, in 40 Gbps systems, we require compensation after just 4 km of transmission whereas in 10 Gbps systems we can go up to 60 km

Effects of PMD at 40 Gbps

- To study the effects of PMD, we emulated different amounts of DGD (differential group delay) using a PMD emulator
- Figure below shows the degradation of eye when we introduce 30 ps of DGD

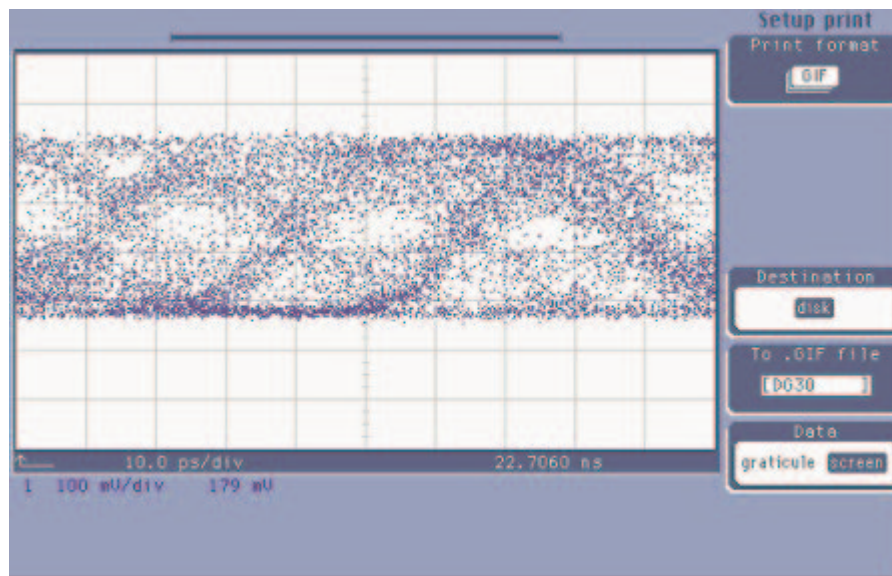

Emulated PMD : 30 ps

Effects of PMD at 40 Gbps

- To compensate for PMD, we tested the adaptive PMD compensation system developed in the laboratory at 40 Gbps
- The PMD monitoring technique is based on the degree of polarization (DOP) of the received optical signal and this mechanism is bit-rate independent

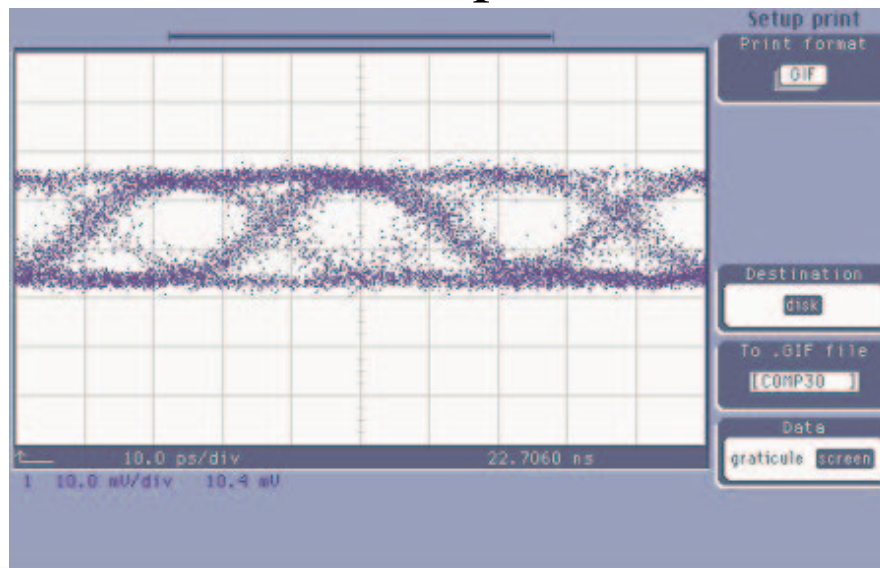

Eye-diagram after compensation. Emulated PMD: 30 ps

Effects of PMD at 40 Gbps

- DOP is a measure of PMD. As the DGD in the link increases, the DOP goes down and vice versa
- Following figure shows the variation of DOP with DGD before and after compensation. We notice a considerable rise in DOP values when we run the compensation system. Thus the PMD compensator was tested successfully at 40 Gbps

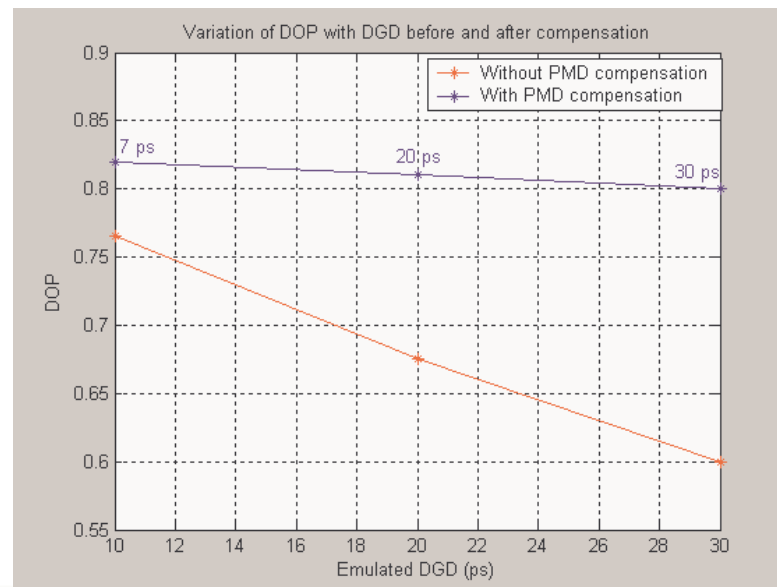

Variation of DOP with DGD before and after compensation

Bench Experiment

- Tested the 40 Gbps system with the PMD compensation system on 10 km spool of SSMF in the laboratory

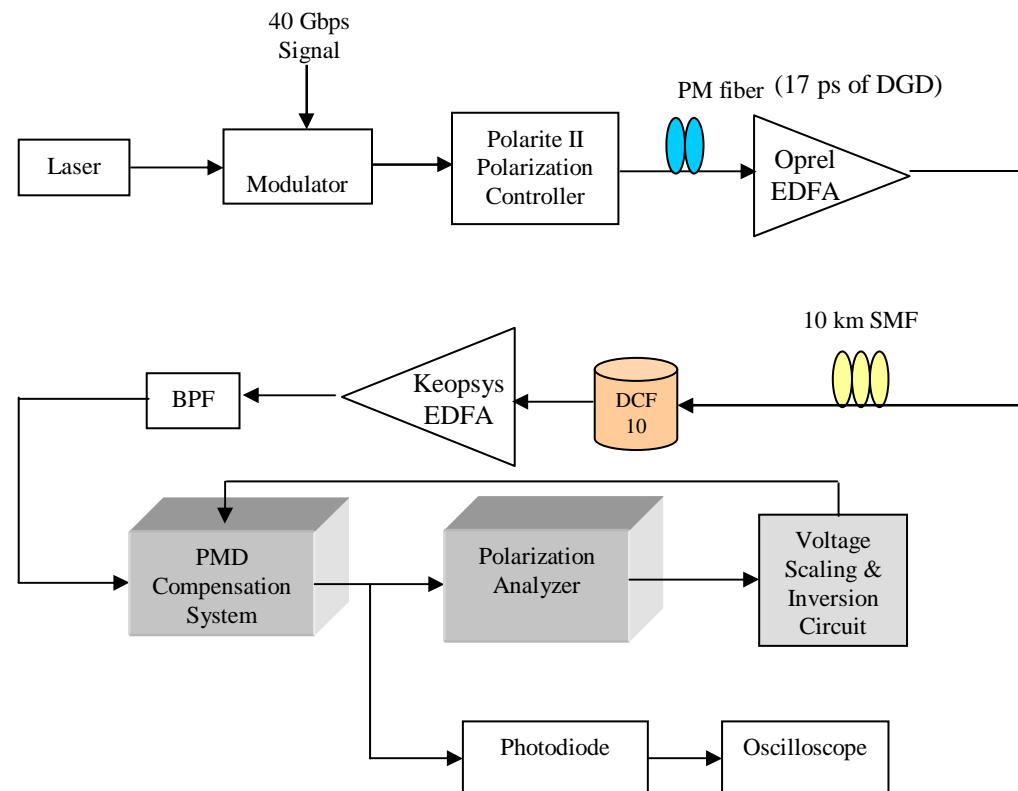

Experimental setup to test the PMD compensation system at 40 Gbps



Bench Experiment

- Device under test: 10 km spool of SMF-28
- Used polarization maintaining fiber (DGD = 17 ps) to emulate PMD in the system
- Employed DCF 10 module to compensate for chromatic dispersion on 10 km spool of fiber

System Parameters:

Operating Wavelength – 1550 nm

Data Rate – 40 Gbps

Waveform – NRZ (non-return-to-zero)

Bit Sequence – PRBS (pseudo random bit sequence), 2^7-1

Bench Experiment

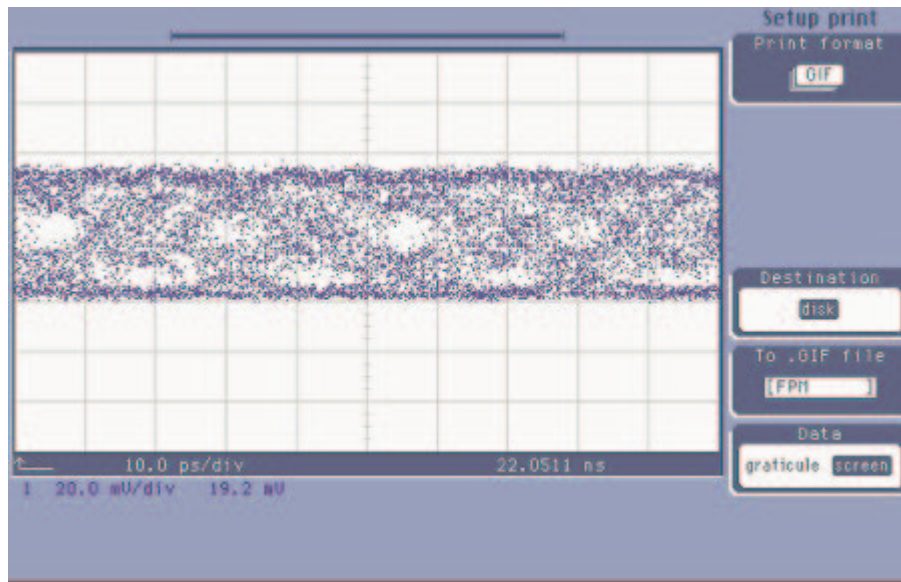

Eye diagram after 10 km of SMF and DCF 10 without PMD compensation

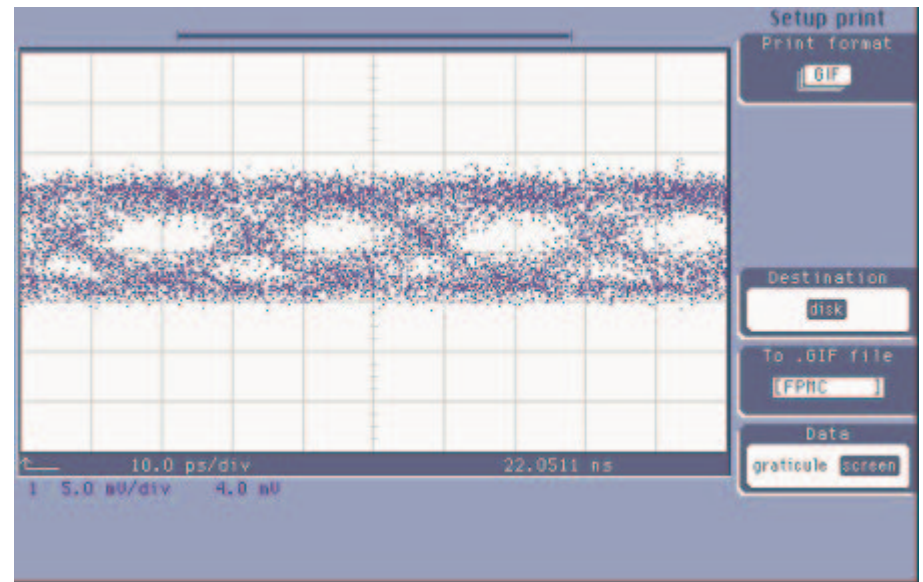

Eye diagram after 10 km of SMF and DCF 10 and PMD compensation

- There is an improvement in signal quality after running the PMD compensation algorithm

Field Trial and Analysis

- Conducted a field trial to send 40 Gbps data on 95 km of buried SSMF. The loss through the link is ~ 40 dB
- To reduce the detrimental effects due to chromatic dispersion at 40 Gbps, we choose to operate at the zero dispersion wavelength
- Employed phase shift method to measure chromatic dispersion on the real link in the laboratory

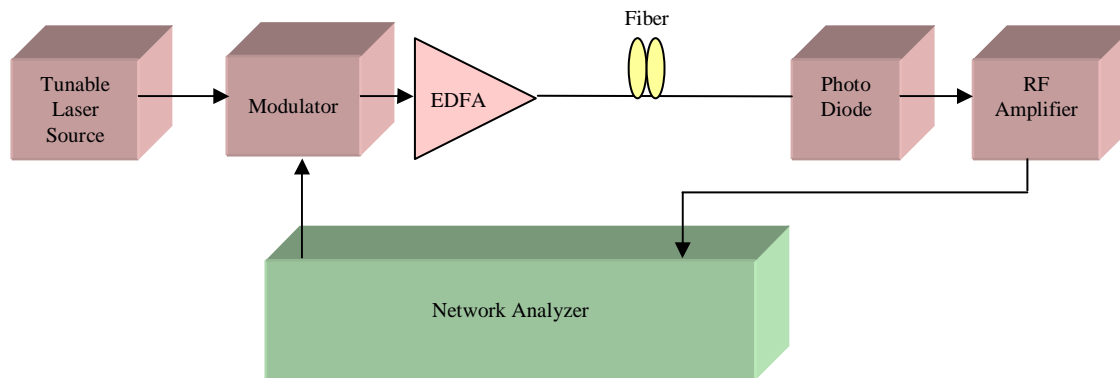

Experimental setup for measuring Chromatic Dispersion

$$D(\lambda_i) = \frac{[\phi(\lambda_{i+1}, f_m) - \phi(\lambda_i, f_m)]}{[2\pi f_m \Delta\lambda_i]}$$

where

λ_i = laser wavelength

f_m = modulation frequency = 1 GHz

$\phi(\lambda_i, f_m)$ = phase

$\Delta\lambda_i = \lambda_{i+1} - \lambda_i = 0.5 \text{ nm}$

Measurement of Chromatic Dispersion

- Curve fitting equation for SMF is $D(\lambda) = (S_o \lambda / 4)(1 - \lambda_o^4 / \lambda^4)$
 $S_o = 0.09 \text{ ps/nm}^2 \text{ km}$; $\lambda_o = 1325 \text{ nm}$

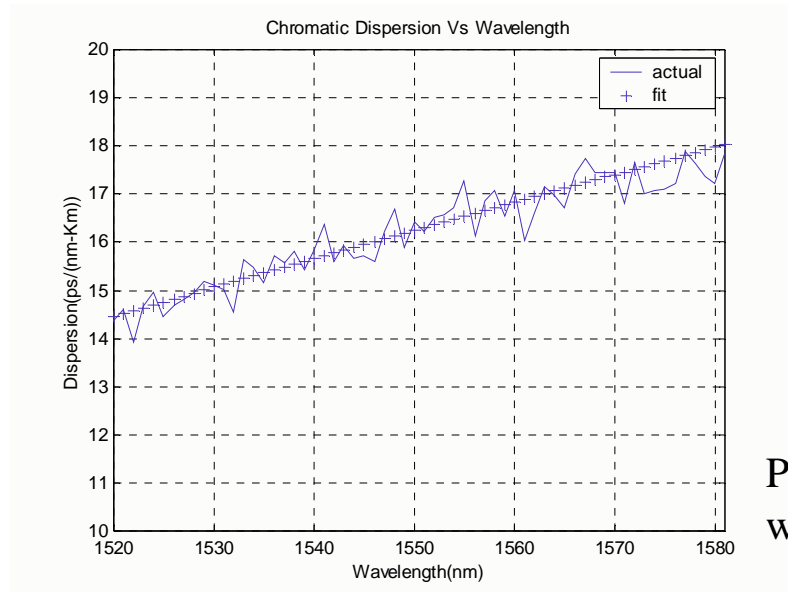

Plot of chromatic dispersion versus wavelength for 5 km of SMF-28

- As expected, SSMF has zero dispersion wavelength of about $1.325 \mu\text{m}$ and positive chromatic dispersion of about 17 ps/nm-km at $1.55 \mu\text{m}$

Measurement of Chromatic Dispersion

- Used a polynomial fit for curve fitting for DCF, $y = ax^2 + bx + c$ where, $a = 0.00085037363$; $b = -2.71044549450$; $c = 2128.76094835080$, $x = \text{wavelength in nm}$
- As expected, DCF has negative dispersion

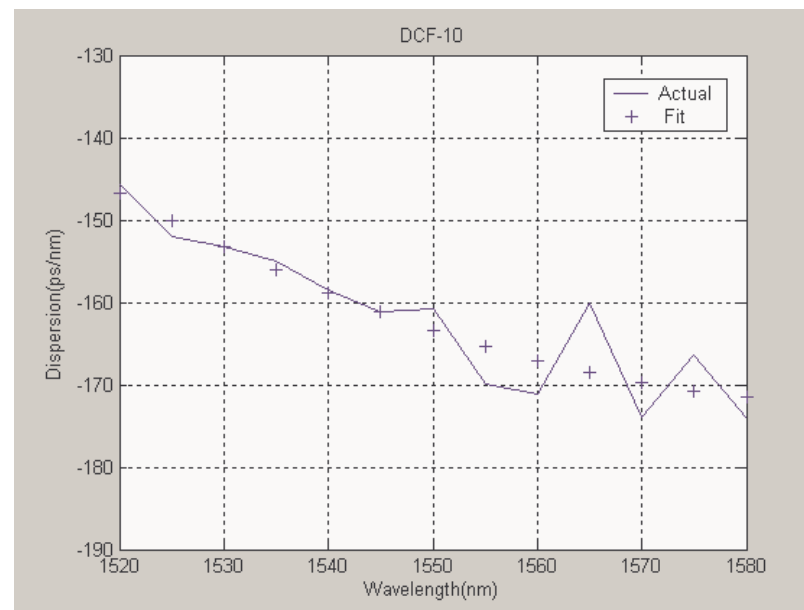

Plot of chromatic dispersion versus wavelength for DCF-10

Compensation of Chromatic Dispersion

- To compensate for chromatic dispersion on 95 km of buried SSMF, we included 18 more km of buried fiber and used DCF 80, DCF 20 and DCF 10 modules. Zero dispersion was achieved at 1542 nm. We operate at this wavelength at 40 Gbps

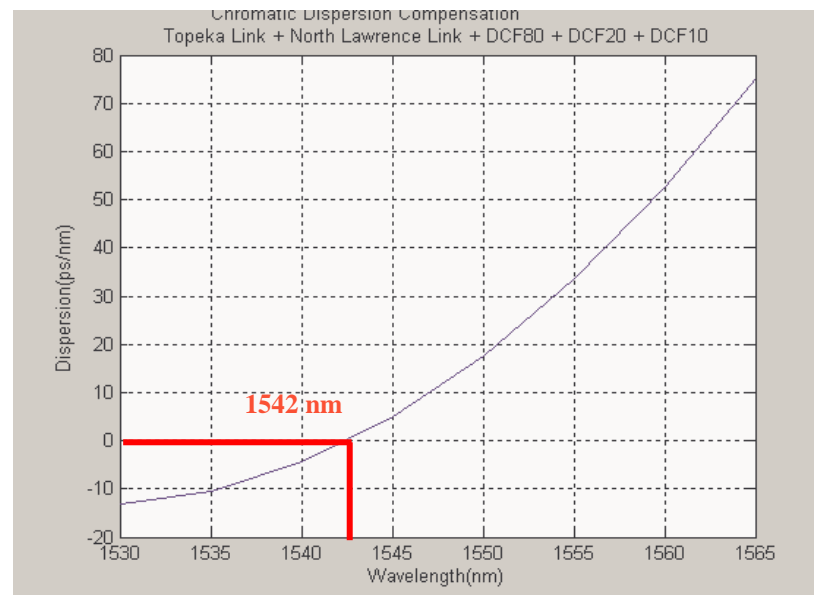

Plot of chromatic dispersion versus wavelength for 95 km of buried SMF-28 after compensation

Measurement of PMD

- To measure the PMD on the link, we used Jones matrix eigen analysis method
- The normalized DGD on the link was found to be 1.11 times the mean DGD at 1542 nm.

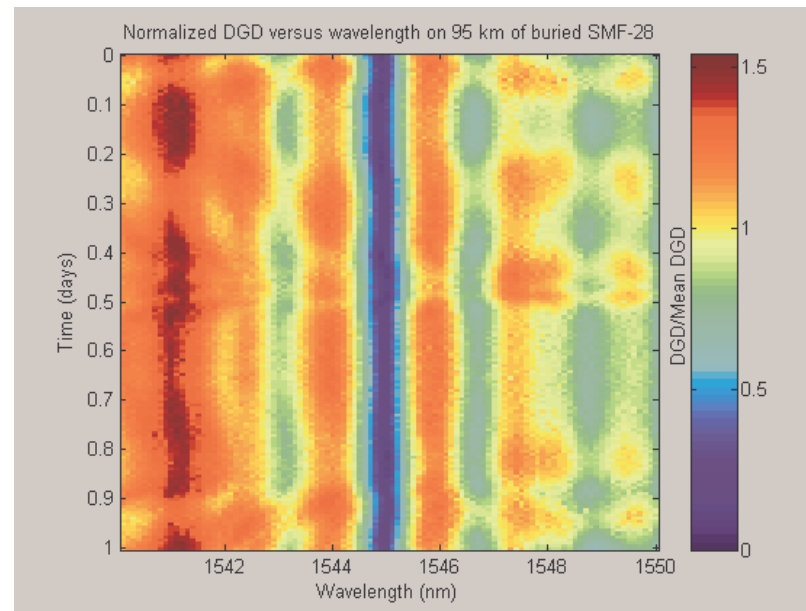

Normalized DGD versus wavelength on 95 km of buried SMF-28

Field Trial and Analysis

- The experimental set-up to send data at 40 Gbps on 95 km of underground fiber-optic link is shown below

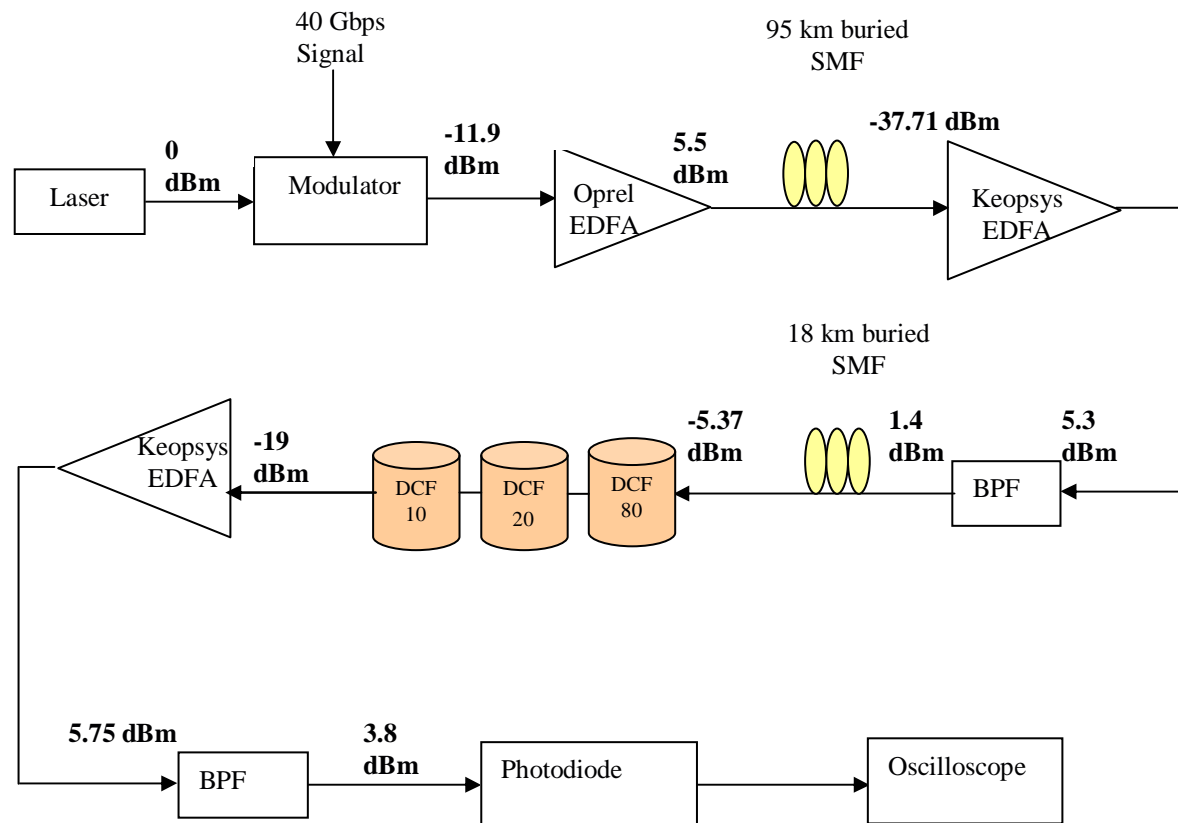

Experimental setup to send data at 40 Gbps on 95 km of buried SMF-28



Field Trial and Analysis

- The output power is maintained below 10 dBm to avoid nonlinearities
- Power entering the DCF modules is kept very low as they are more susceptible to nonlinearities because they have a smaller core diameter
- Power budget analysis was done to reduce the impact of optical amplifier noise

System Parameters:

Operating Wavelength – 1542 nm

Data Rate – 40 Gbps

Waveform – NRZ (non-return-to-zero)

Bit Sequence – PRBS (pseudo random bit sequence), 2^7-1

Field Trial and Analysis

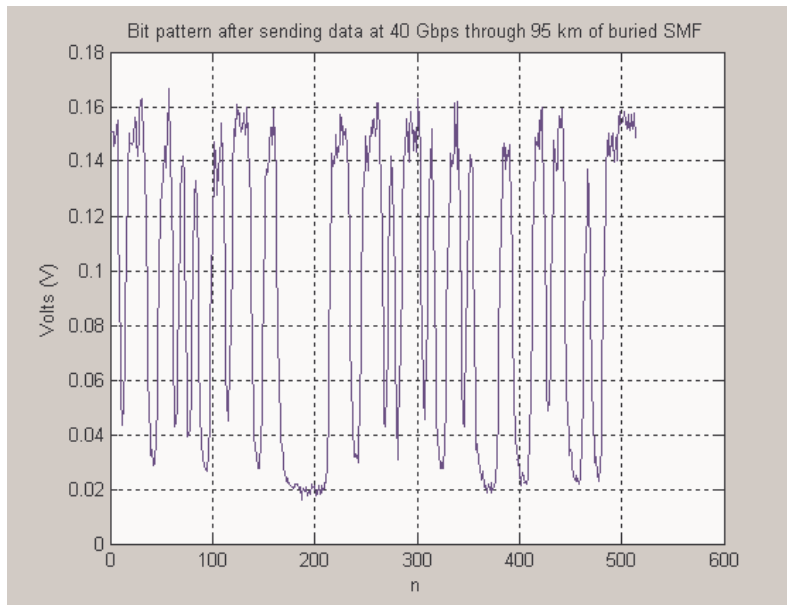

Averaged Bit pattern (16 sample averages) after sending data at 40 Gbps through 95 km of buried SMF-28

- The BER can be calculated from the Q factor

$$BER = \frac{1}{2} \operatorname{erfc}\left(\frac{Q}{\sqrt{2}}\right) \approx \frac{1}{\sqrt{2\pi}} \frac{e^{-\frac{Q^2}{2}}}{Q}$$

- Q is defined as

$$Q = \frac{I_1 - I_0}{\sqrt{\sigma_1^2} + \sqrt{\sigma_0^2}}$$



Field Trial and Analysis

- The value of Q is calculated to be 1.6537
- The BER of the system is 6.1×10^{-2} . This is because the SNR of the system is very poor. The system is highly noise limited
- We could not include the PMD compensation system in the field trial because of poor SNR
- The SNR after the first Keopsys EDFA is 15.68 dB. The noise figure of Keopsys EDFA at 1542 nm is 4 dB
- Therefore, the SNR at the output of second Keopsys EDFA is calculated to be 11.68 dB
- Presence of PMD and poor SNR cause the DOP to go down

Field Trial and Analysis

- Performed an experiment to find out the minimum SNR that should be maintained to get a good polarized signal

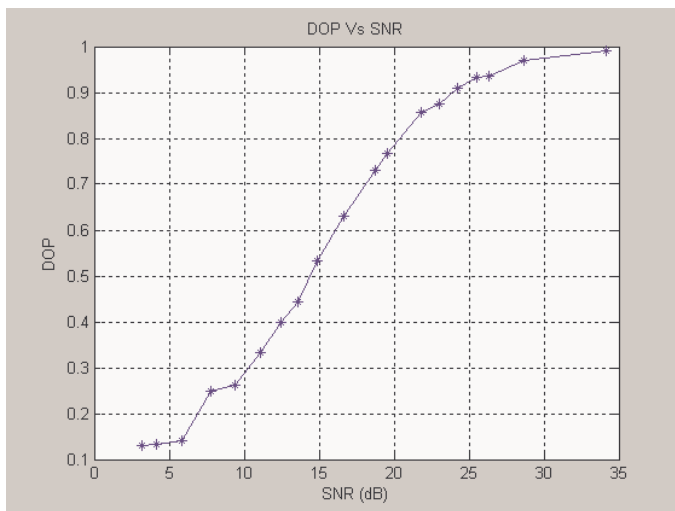

Variation of DOP with SNR

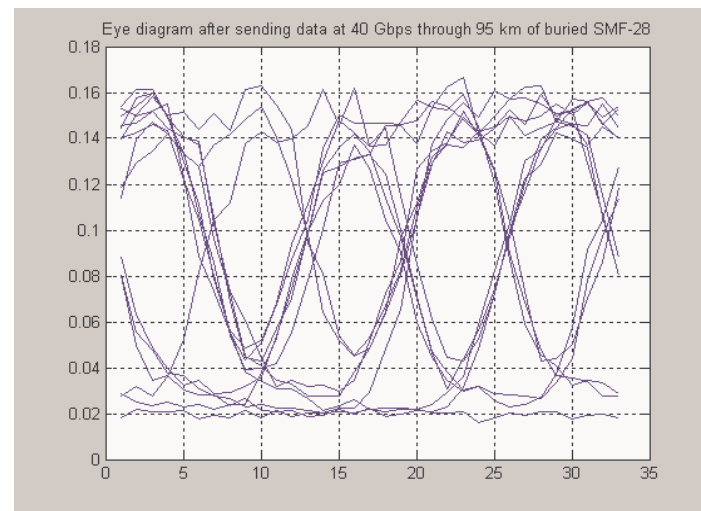

Eye diagram after sending data at 40 Gbps through 95 km of buried SMF-28

- To get a DOP of 90 %, SNR of about 25 dB should be maintained. SNR of 11.68 dB corresponds to a DOP of 35 %. There is a huge reduction in DOP due to poor SNR



Conclusions and Suggestions for Future Work

- The 10 Gbps BERT was upgraded to 40 Gbps pattern generator
- Signal is largely affected by chromatic dispersion and dispersion compensation has to be employed for very short distances at 40 Gbps
- The adaptive PMD compensation system was tested successfully at this high bit rate
- The system was mainly limited by noise on the underground fiber-optic link
- To improve the SNR of the system, we need to place EDFAs along the real link to boost the signal periodically and avoid signal degradation



Conclusions and Suggestions for Future Work

- To accurately measure the BER of the system, we need a clock recovery unit to avoid problems with the misalignment between the BERT clock and the signal
- Tunable chromatic dispersion compensation to compensate accurately at 40 Gbps
- The 40 Gbps system with the PMD compensation system can be tested for different modulation formats such as RZ and CS-RZ (carrier suppressed return-to-zero)

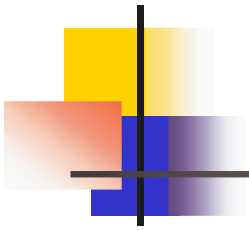

THANK YOU