

A CROSS-LAYER SCHEME FOR TCP PERFORMANCE IMPROVEMENT IN WIRELESS LANS

Student Presentation

EECS 800 Survivable, Resilient, and Disruption Tolerant Networking

Piyush Upadhyay

The University of Kansas, Department of Electrical & Computer Science

piyush@ku.edu

Primary Reference

- Dzmitry Kliazovich and Fabrizio Granelli,
“A Cross-Layer Scheme for TCP Performance Improvement in
Wireless LANs”,
Proceedings of IEEE GLOBECOM 2005,
Dallas, Nov.–Dec. 2004, pp. 840–844.

Outline

- Transport Layer Control : Different approaches
- Proposed Scheme: LLE-TCP
 - Motivation
 - The ARQ Snoop agent
 - Comparison of the behavior of original TCP and LLE-TCP schemes
- Experimental Results
- Advantage
- Limitations
- Conclusion and future work

Transport Layer Control : Different approaches

- Connection Splitting Solution
 - end-to-end TCP connection is divided in to fixed and wireless parts
- Link Layer Solution
 - make the wireless link layer look similar to the wired case of TCP
- TCP modification
 - SACK, Fast retransmit, FACK
- Cross-Layer Design
 - Break the layering principle by allowing interdependence and joint design of protocols crossing different layers

Proposed Scheme: LLE-TCP

- Motivation

- Two ARQ schemes, one at Transport layer other at Link layer
- Non optimal utilization of the available network resources
- ARQ is involved three times at different layers of protocol stack for the delivery of single TCP data packet
- exploit the information of the link layer ARQ for a more efficient acknowledgement of TCP packet delivery
- ARQ Snoop agent.

Proposed Scheme: LLE-TCP

- ARQ Snoop Agent
 - Software Module
 - Agent Interaction with the Link Layer
 - PACK_DELIVERED event
 - PACK_UNDELIVERED event
 - Interaction is Unidirectional
 - Agent Interaction with Transport layer
 - Sender side : store relevant information and wait for link layer event
 - Receiver side: drop packets with ACK flag set
 - Acknowledgement generation module

Proposed Scheme: LLE-TCP

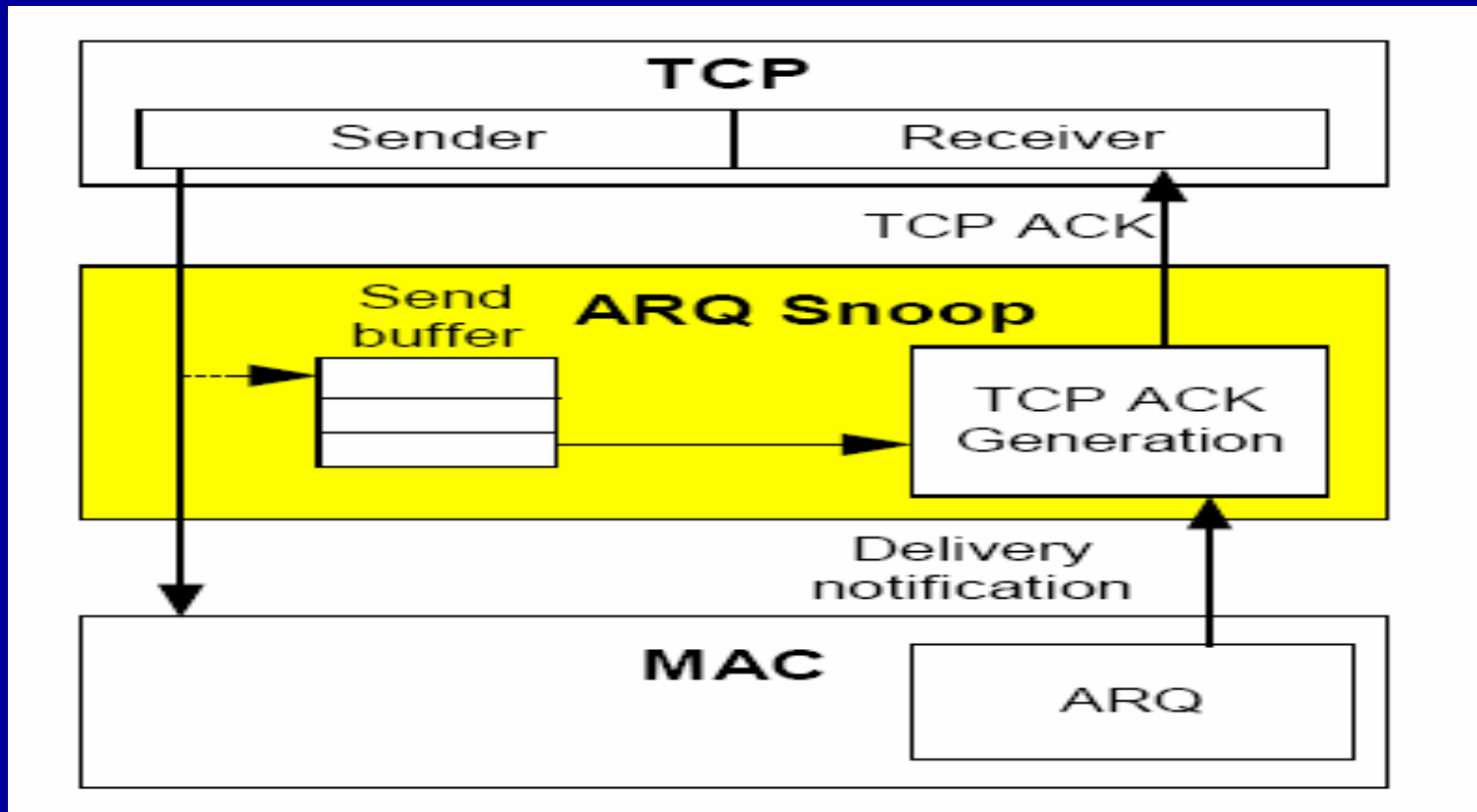

A view of the protocol stack of the wireless node, where the position of ARQ Snoop agent as well as its relationship with the transport and MAC layers is illustrated.

Comparison of the behavior of original TCP and LLE-TCP schemes

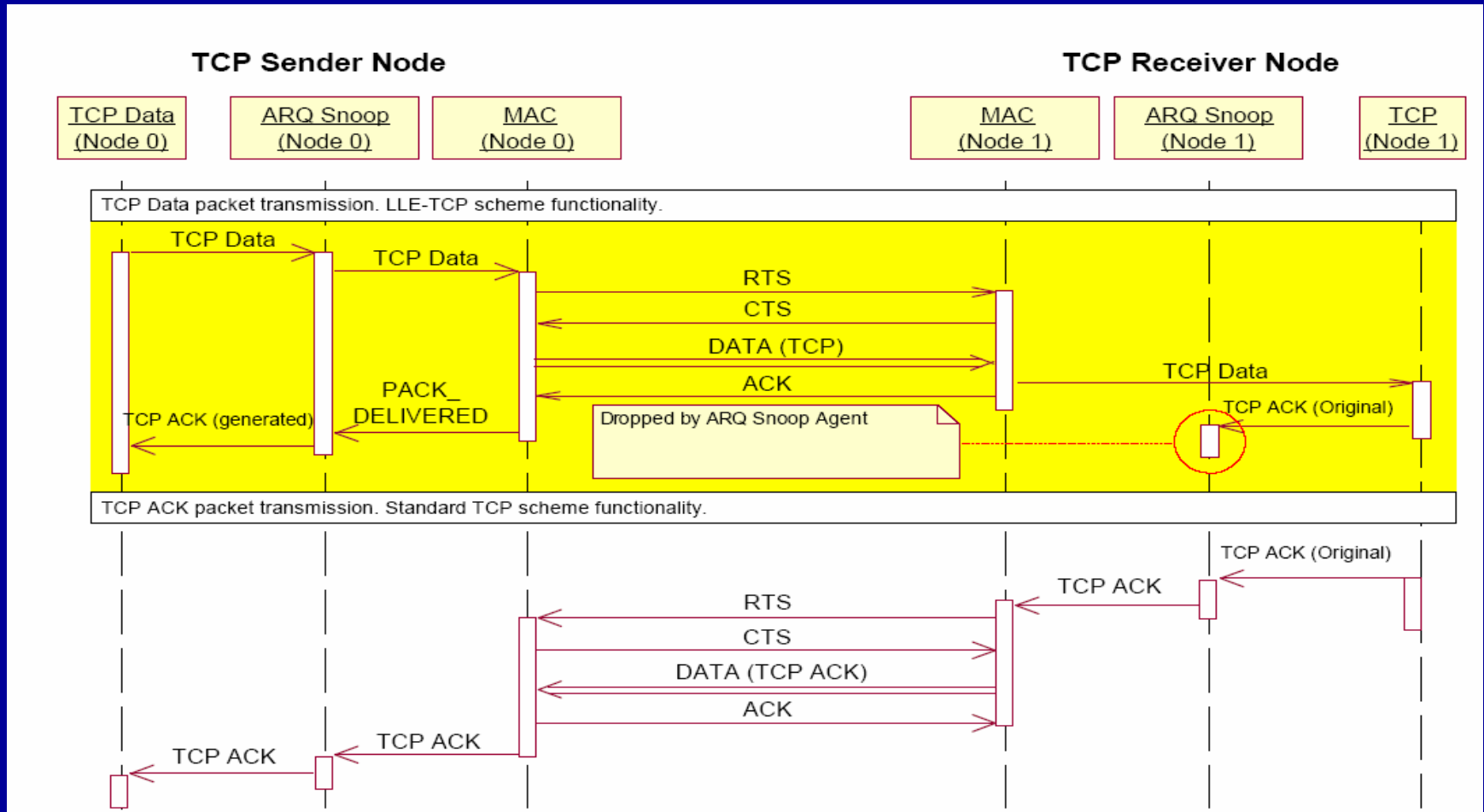

Experimental Setup

- Grid topology
- Two static nodes are linked through a single TCP connection
- Packet size = 1KB
- Performance analysis criterion : Throughput
- Resulting Throughput values are compared against standard TCP scheme over a 1Mbps IEEE 802.11 wireless link with two-ray ground propagation model.

Experimental Results

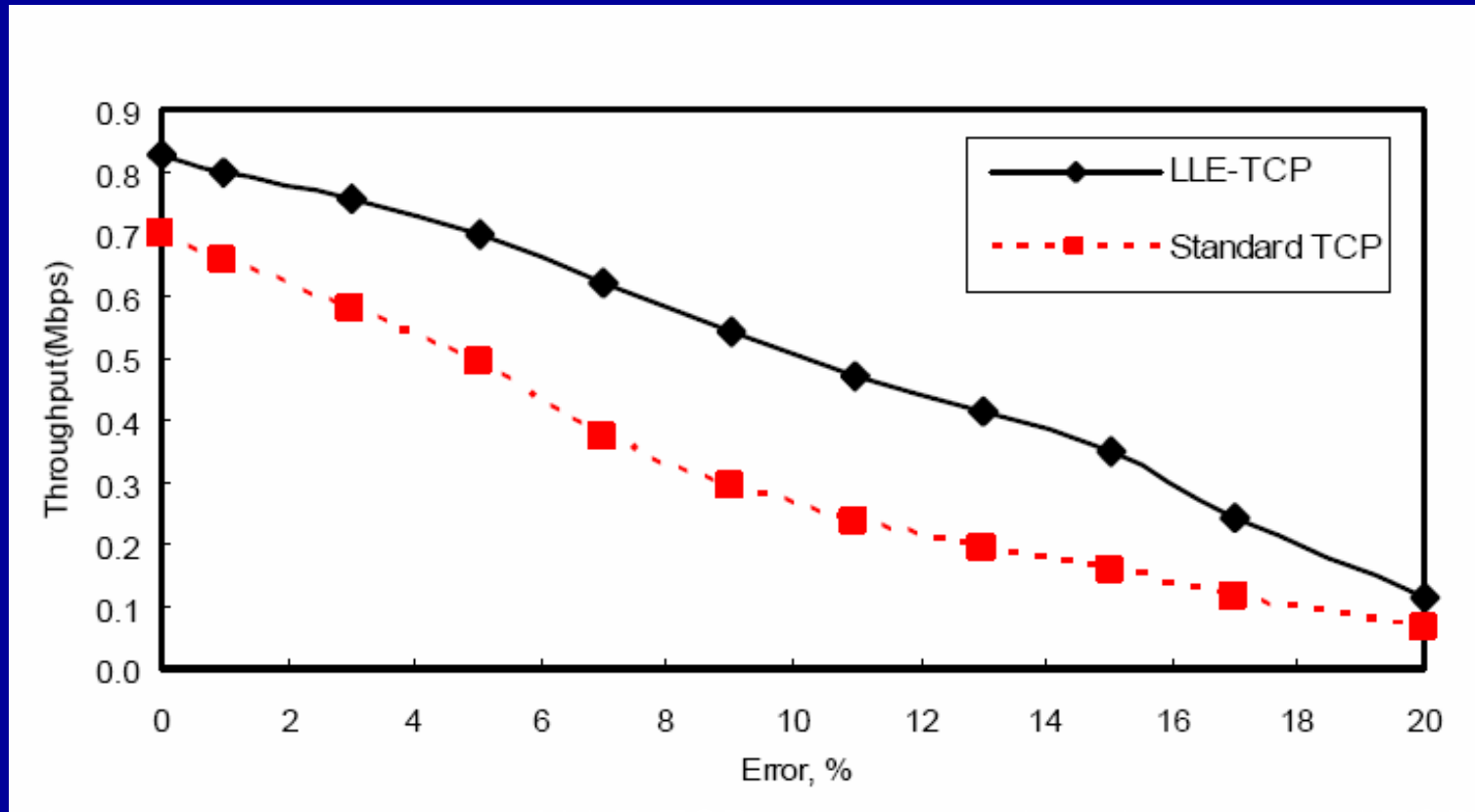

Performance comparison of LLE-TCP scheme against the standard TCP implementation (TCP Tahoe).

Experimental Results

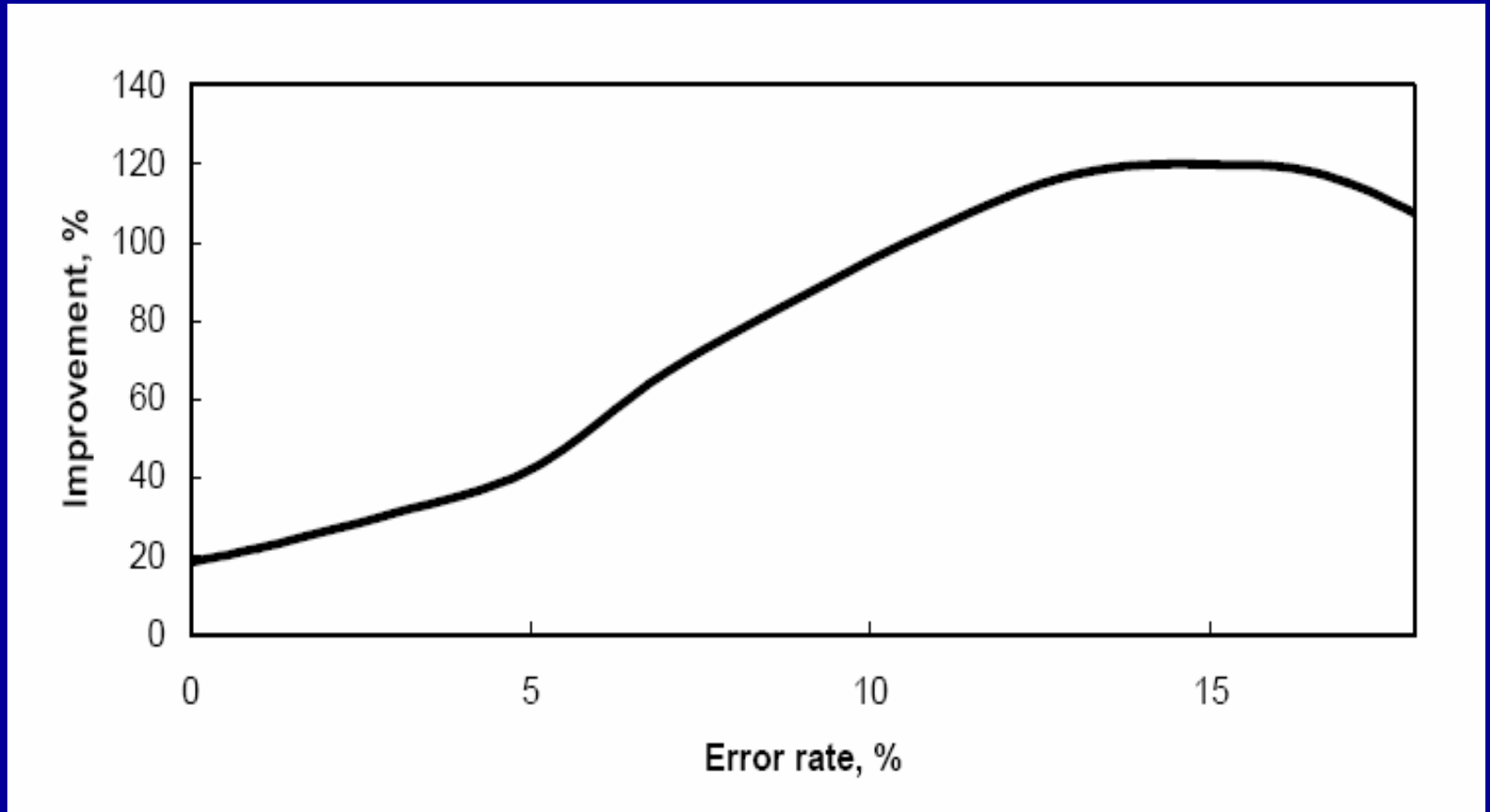

Improvement achieved by LLE-TCP against TCP Tahoe on a 802.11 WLAN

Experimental Results

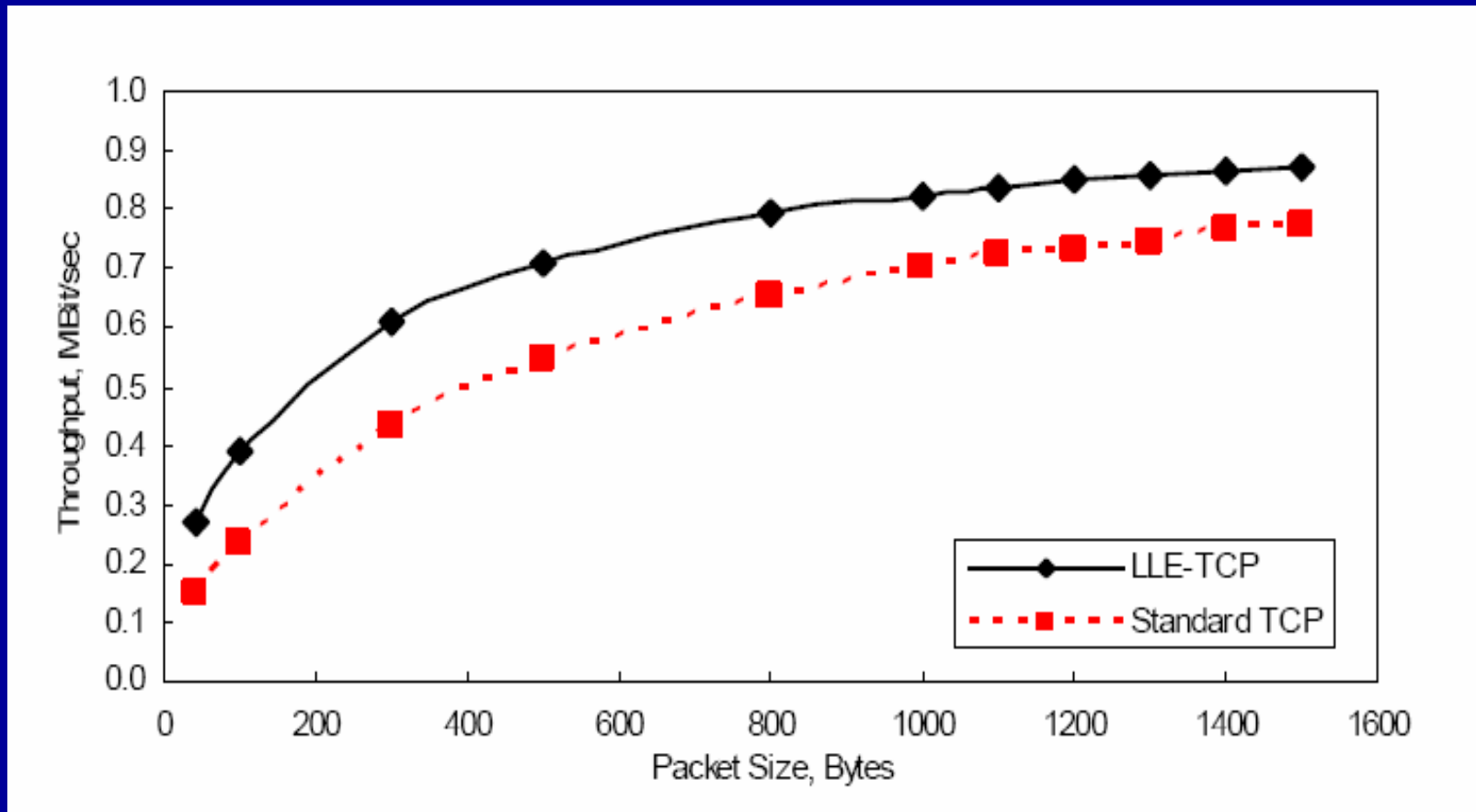

Comparison of throughput level of LLE-TCP against TCP Tahoe for different packet sizes.

Experimental Results

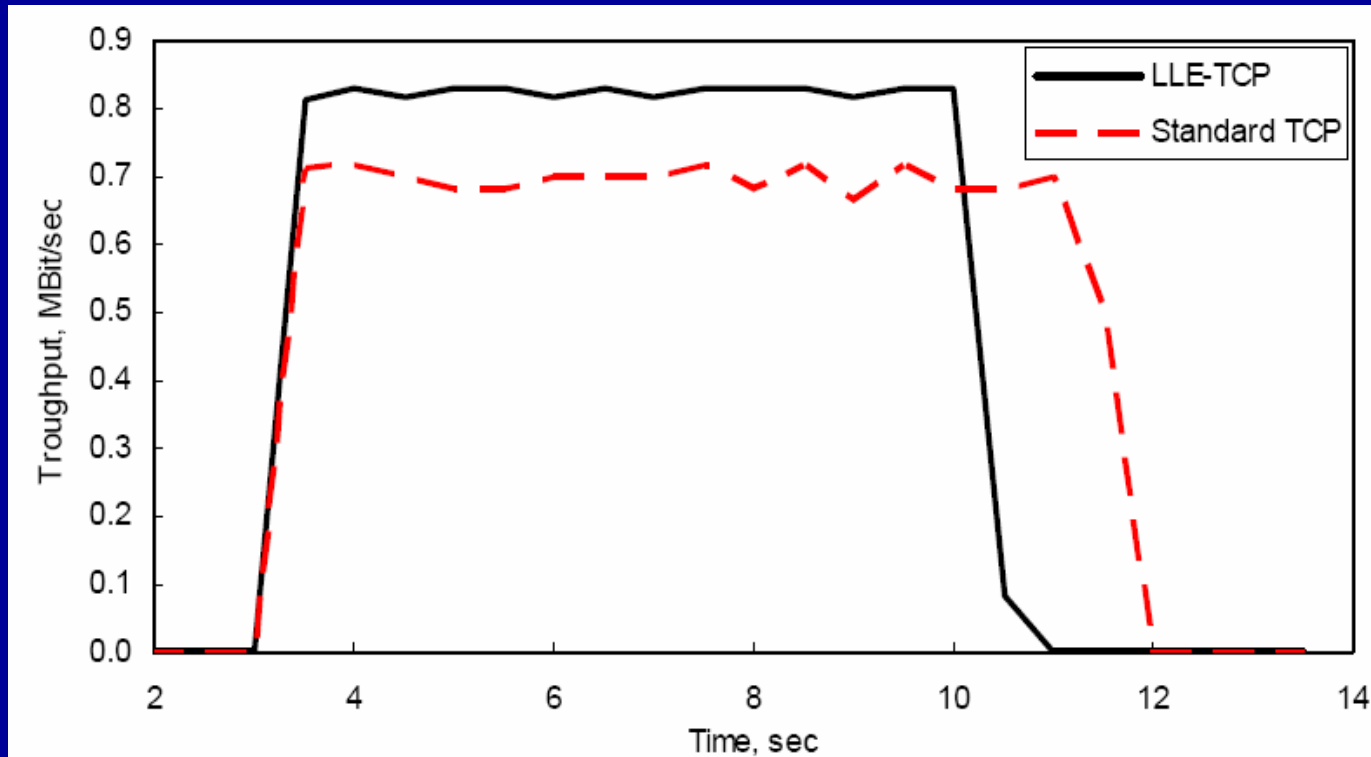

Throughput level of LLE-TCP and Standard TCP for the transmission of a 700 KB file.

Experimental Results

Type of TCP	Achieved Improvement	
	Normal	Other conditions
LLE-TCP	18 %	Up to 120 %
ILC-TCP	-	Up to 30 %
I-TCP	About 7 %	Up to 53 %

COMPARISON OF LLE-TCP AGAINST COMPETING APPROACHES

LLE-TCP: Advantages

- Advantages of LLE-TCP
 - reduction of medium busy time for the transmission of TCP ACK packets over the wireless channel
 - Improvement is dependent on TCP packet size and channel error rate
 - A passive reduction of channel error rate

LLE-TCP: Limitations

- Limitations of LLE-TCP
 - Requirement of resources at the sender side for traffic analysis and ACK generation

Conclusion

- This paper presented a novel approach for the performance enhancement of TCP over wireless infrastructures (such as WLANs). The advantages in terms of throughput jointly achieved by cross-layer collaboration technique and link layer ARQ exploitation for improving the acknowledgement scheme of the TCP are presented.
- The performance is evaluated through extensive simulations with different implementations of TCP by comparing the results with standard TCP scheme of the protocol stack as well with other approaches in this area. Results underline significant advantages of the designed scheme in any channel error condition.