

Example: Another Small-Signal Analysis of a MOSFET Amplifier

Let's determine the small-signal voltage gain $A_v = v_o/v_i$ (note not the open-circuit gain!) of the following amplifier:

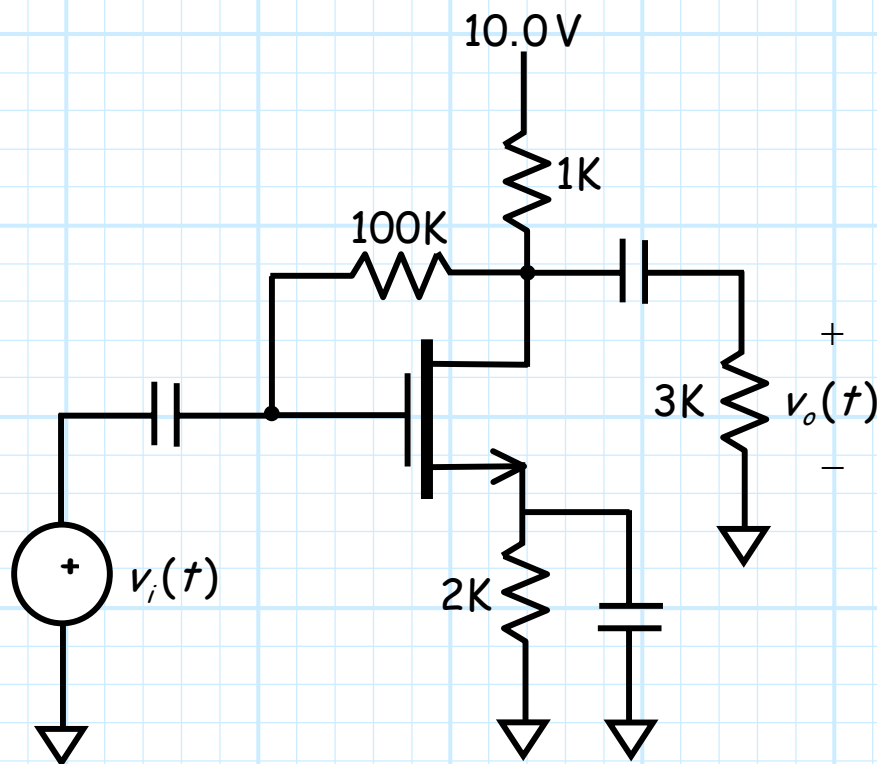

$$\begin{aligned} \lambda &= 0.005 \text{ V}^{-1} \\ K &= 0.4 \text{ mA/V}^2 \\ V_T &= 2.0 \text{ V} \\ C\text{'s are large} \end{aligned}$$

Step 1: DC Analysis

Capacitors are **open** circuits at DC, therefore the DC circuit is:

We **ASSUME** the MOSFET is in saturation, thus we **ENFORCE**:

$$I_D = K(V_{GS} - V_t)^2$$

Since $I_G = 0$, we find that $V_G = V_D$, and thus $V_{GS} = V_{DS}$. From KVL, we find:

$$10.0 - (1)I_D - V_{DS} - (2)I_D = 0$$

Or since $V_{GS} = V_{DS}$:

$$V_{GS} = 10.0 - 3I_D$$

Combining this with $I_D = K(V_{GS} - V_t)^2$, we get a **quadratic equation** of V_{GS} :

$$V_{GS} = 10.0 - 3K(V_{GS} - V_t)^2$$

The **solutions** to this equation are:

$$V_{GS} = 4.2 \text{ V} \quad \text{and} \quad V_{GS} = -1.0 \text{ V}$$

Don't panic! Only **one** of these solutions satisfy our saturation assumption: $V_{GS} = 4.2 > 2.0 = V_t$.

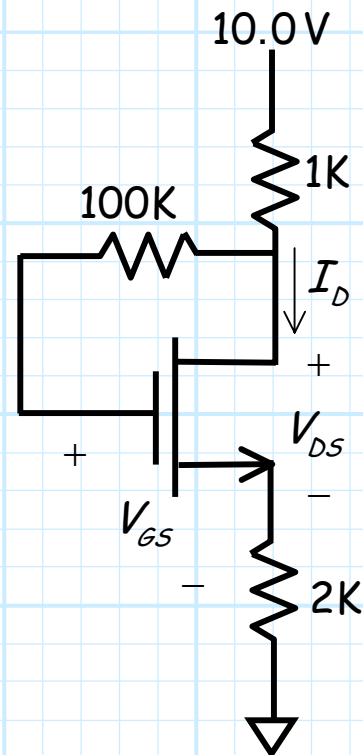

Step 2: Determine Small-Signal Parameters

$$\begin{aligned} g_m &= 2K(V_{GS} - V_t) \\ &= 2(0.4)(4.2 - 2.0) \\ &= 1.76 \text{ mA/V} \end{aligned}$$

$$\begin{aligned} r_o &= \frac{1}{\lambda K(V_{GS} - V_t)^2} \\ &= \frac{1}{0.005(0.4)(4.2 - 2.0)^2} \\ &= 103 \text{ K}\Omega \end{aligned}$$

Steps 3 and 4: Determine the small-signal circuit

- Turn **off** the DC voltage source.
- Replace the large capacitors with **short** circuits.

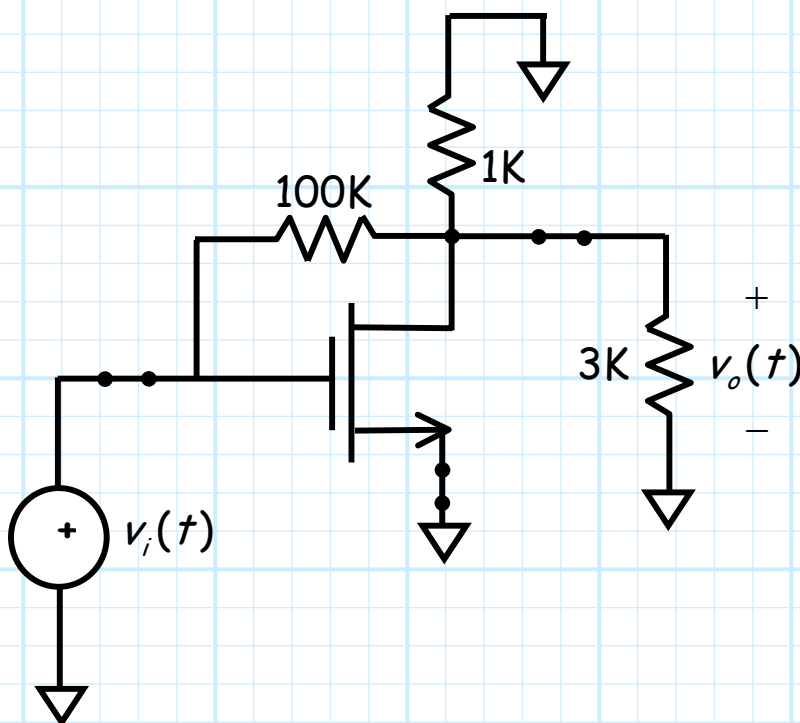

c) Replace the MOSFET with its **small-signal model**.

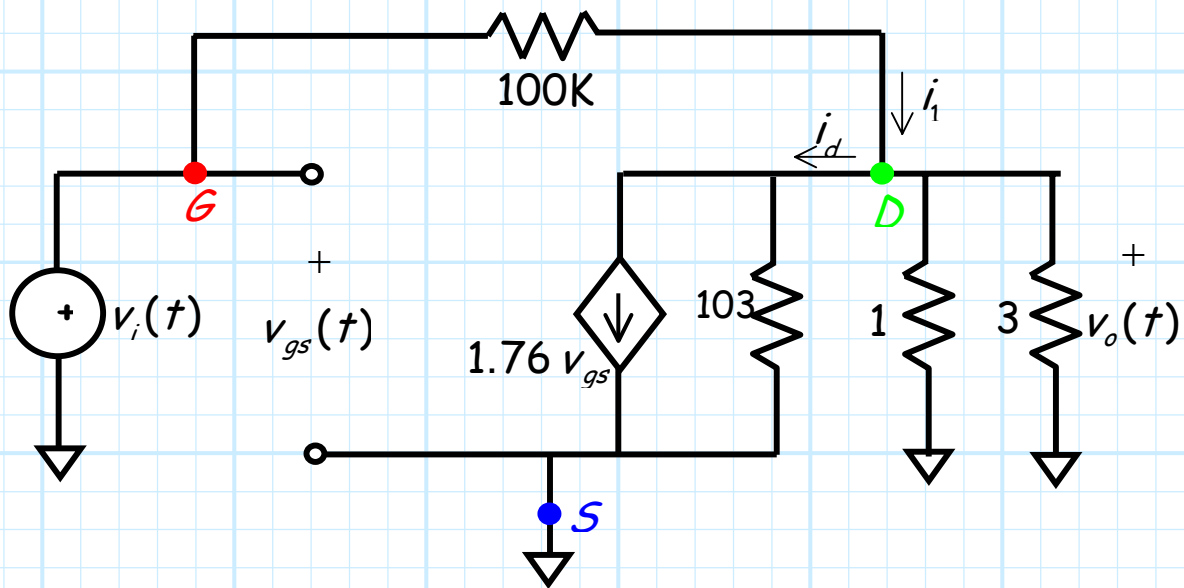

We find first that $v_{gs} = v_i$. We likewise see from KCL that current i_1 is:

$$\begin{aligned} i_1 &= 1.76 v_{gs} + \frac{v_o}{1} + \frac{v_o}{3} + \frac{v_o}{103} \\ &= 1.76 v_i + 1.334 v_o \end{aligned}$$

From Ohm's Law, we likewise find that i_1 is:

$$i_1 = \frac{v_i - v_o}{100}$$

Combining these two equations, we find:

$$v_i - v_o = 176 v_i + 133.4 v_o$$

And from this we find that the **small-signal voltage gain** is:

$$A_v = \frac{v_o}{v_i} = \frac{-175}{134.4} = -1.31 \quad \text{not much gain!}$$