

Chapter - 7 Power Dividers and Couplers

One of the most fundamental problems in microwave engineering is how to efficiently **divide** signal power.

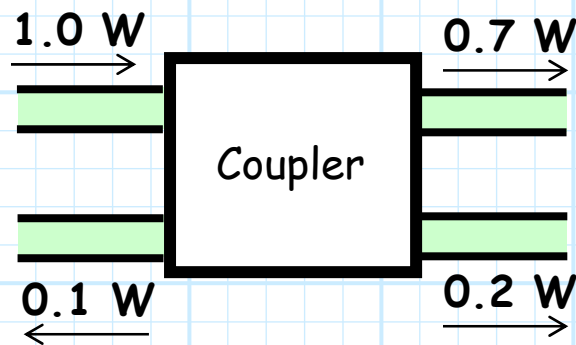

The **simplest** microwave problem would seemingly be to **equally** divide signal power in two:

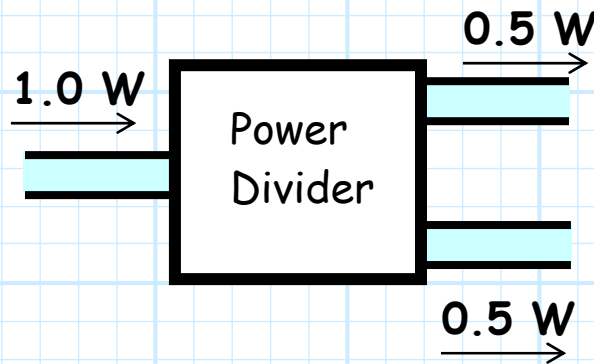

However, building these devices is **more difficult** than you might think!

7.1 - Basic Properties of Dividers and Couplers

Reading Assignment: *pp. 308-315*

First let's examine four-port networks called **directional couplers**, and explain some fundamental values that characterize them.

HO: THE DIRECTIONAL COUPLER

The Directional Coupler

A **directional coupler** is a 4-port network that is designed to **divide** and **distribute** power.

Although this would seem to be a particularly **mundane** and simple task, these devices are both very **important** in microwave systems, and very **difficult** to design and construct.



Two of the **reasons** for this difficulty are our desire for the device to be:

1. Matched
- B. Lossless

Thus, we require a **matched**, **lossless**, and (to make it simple) **reciprocal** 4-port device!

Recall that a matched, lossless, reciprocal, 4-port device was difficult to even **mathematically** determine, as the resulting scattering matrix must be (among other things) **unitary**.

However, we were able to determine two possible mathematical solutions, which we called the **symmetric** solution:

$$\mathcal{S} = \begin{bmatrix} 0 & \alpha & j\beta & 0 \\ \alpha & 0 & 0 & j\beta \\ j\beta & 0 & 0 & \alpha \\ 0 & j\beta & \alpha & 0 \end{bmatrix}$$

And the **asymmetric** solution:

$$\mathcal{S} = \begin{bmatrix} 0 & \alpha & \beta & 0 \\ \alpha & 0 & 0 & -\beta \\ \beta & 0 & 0 & \alpha \\ 0 & -\beta & \alpha & 0 \end{bmatrix}$$

wherein for both cases, the relationship:

$$|\alpha|^2 + |\beta|^2 = 1$$

must be true in order for the device to be **lossless** (i.e., for \mathcal{S} to be unitary).

For most couplers we will find that α and β can (at least ideally) be represented by a real value c , known as the **coupling coefficient**.

$$\beta = c \qquad \alpha = \sqrt{1 - c^2}$$

The **symmetric** solution is thus described as:

$$\mathcal{S} = \begin{bmatrix} 0 & \sqrt{1-c^2} & jc & 0 \\ \sqrt{1-c^2} & 0 & 0 & jc \\ jc & 0 & 0 & \sqrt{1-c^2} \\ 0 & jc & \sqrt{1-c^2} & 0 \end{bmatrix}$$

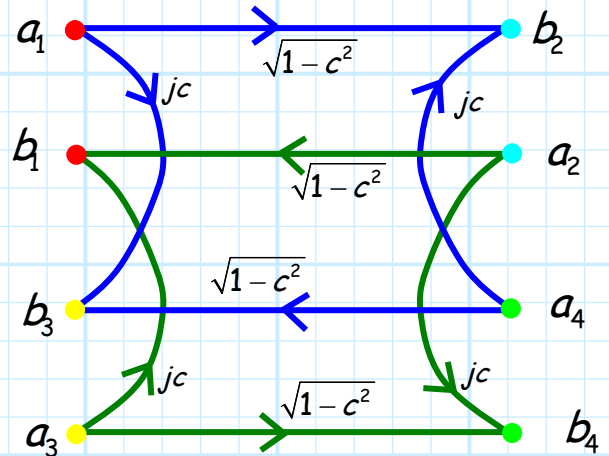

And the **asymmetric** solution is:

$$\mathcal{S} = \begin{bmatrix} 0 & \sqrt{1-c^2} & c & 0 \\ \sqrt{1-c^2} & 0 & 0 & -c \\ c & 0 & 0 & \sqrt{1-c^2} \\ 0 & -c & \sqrt{1-c^2} & 0 \end{bmatrix}$$

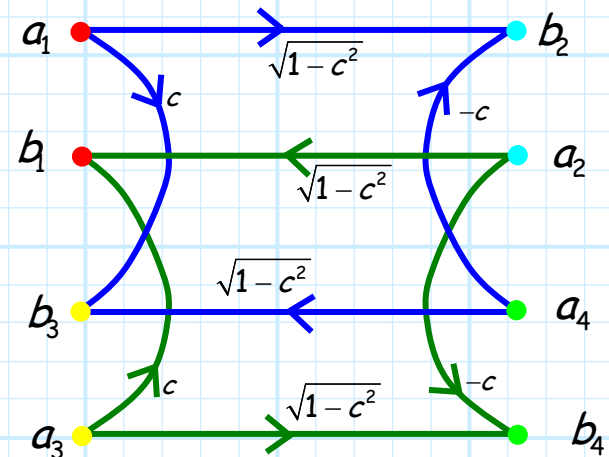

Additionally, for a directional coupler, the coupling coefficient c will be less than $1/\sqrt{2}$ **always**. Therefore, we find that:

$$0 \leq c \leq \frac{1}{\sqrt{2}} \quad \text{and} \quad \frac{1}{\sqrt{2}} \leq \sqrt{1-c^2} \leq 1$$

Let's see what this means in terms of the **physical behavior** of a directional coupler. First, consider the case where some signal is incident on **port 1**, with power P_1^+ .

If all other ports are matched, we find that the power flowing out of **port 1** is:

$$P_1^- = |S_{11}|^2 P_1^+ = 0^2 P_1^+ = 0$$

while the power out of **port 2** is:

$$P_2^- = |S_{21}|^2 P_1^+ = (1 - c^2) P_1^+$$

and the power out of **port 3** is:

$$P_3^- = |S_{31}|^2 P_1^+ = c^2 P_1^+$$

Finally, we find there is **no power** flowing out of **port 4**:

$$P_4^- = |S_{41}|^2 P_1^+ = 0^2 P_1^+ = 0$$

In the terminology of the directional coupler, we say that port 1 is the **input** port, port 2 is the **through** port, port 3 is the **coupled** port, and port 4 is the **isolation** port.

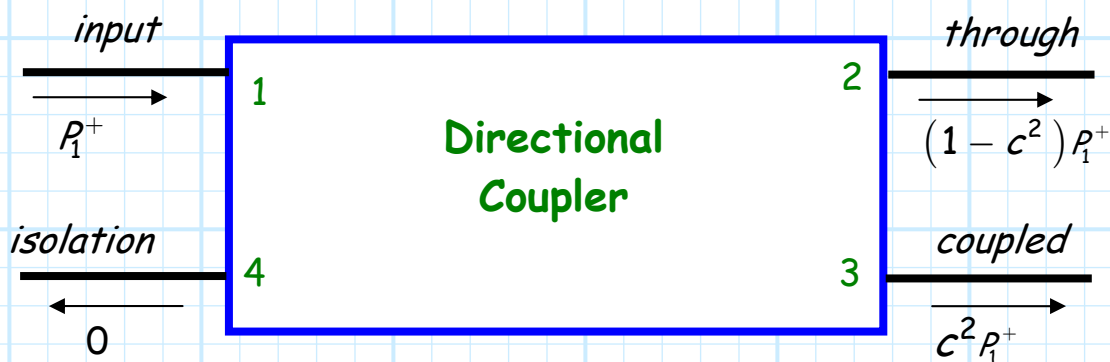

Note however, that **any** of the coupler ports can be an input, with a different through, coupled and isolation port for each case.

For example, if a signal is incident on **port 2**, while all other ports are matched, we find that:

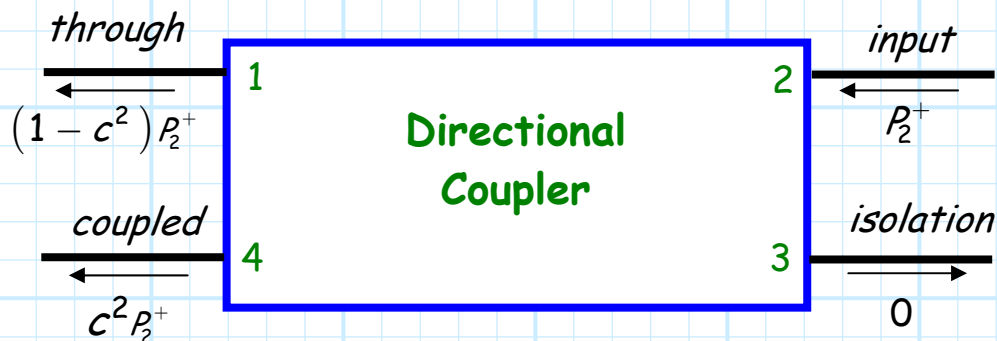

Thus, from the scattering matrix of a directional coupler, we can form the following table:

<i>Input</i>	<i>Through</i>	<i>Coupled</i>	<i>Isolation</i>
Port 1	Port 2	Port 3	Port 4
Port 2	Port 1	Port 4	Port 3
Port 3	Port 4	Port 1	Port 2
Port 4	Port 3	Port 2	Port 1

Typically, the coupling coefficients for a directional coupler are in the range of approximately:

$$0.25 > c^2 > 0.0001$$

As a result, we find that $\sqrt{1 - c^2} \approx 1$. What this means is that the power out of the **through** port is just **slightly smaller** (typically) than the power incident on the input port.

Likewise, the power out of the **coupling** port is typically a **small fraction** of the power incident on the input port.



Q: *Pfft! Just a **small fraction** of the input power! What is the use in doing that??*

A: A directional coupler is often used for **sampling** a small portion of the signal power. For example, we might **measure** the output power of the **coupled** port (e.g., P_3^-) and then we can determine the amount of signal power flowing through the device (e.g., $P_1^+ = P_3^- / c^2$)

Unfortunately, the **ideal** directional coupler **cannot** be built! For example, the input match is never **perfect**, so that the diagonal elements of the scattering matrix, although **very small**, are not zero.

Likewise, the isolation port is never **perfectly** isolated, so that the values S_{41} , S_{32} , S_{23} and S_{14} are also non-zero—some **small** amount of power leaks out!

As a result, the through port will be **slightly less** than the value $\sqrt{1 - c^2}$. The scattering matrix for a **non-ideal coupler** would therefore be:

$$\mathcal{S} = \begin{bmatrix} S_{11} & S_{21} & jc & S_{41} \\ S_{21} & S_{11} & S_{41} & jc \\ jc & S_{41} & S_{11} & S_{21} \\ S_{41} & jc & S_{21} & S_{11} \end{bmatrix}$$

From **this** scattering matrix, we can extract **some important parameters** about directional couplers:

Coupling C

The **coupling** value is the ratio of the coupled output power (P_3^-) to the input power (P_1^+), expressed in decibels:

$$C (dB) = 10 \log_{10} \left[\frac{P_1^+}{P_3^-} \right] = -10 \log_{10} |jc|^2$$

This is the **primary** specification of a directional coupler!

Note the **larger** the coupling value, the **smaller** the coupled power! For example:

A 6 dB coupler couples out 25% of the input power.

A **10 dB** coupler couples out **10%** of the input power.

A **20 dB** coupler couples out **1.0%** of the input power.

A **30 dB** coupler couples out **0.1%** of the input power.

Directivity D

The **directivity** is the ratio of the power **out** of the coupling port (P_3^-) to the power **out** of the isolation port (P_4^-), expressed in decibels.

$$D(dB) = 10 \log_{10} \left[\frac{P_3^-}{P_4^-} \right] = 10 \log_{10} \left[\frac{|j_c|^2}{|S_{41}|^2} \right]$$

This value indicates how effective the device is in "**directing**" the coupled energy into the correct port (i.e., into the coupled port, **not** the isolation port).

Ideally this is infinite (i.e., $P_4^- = 0$), so the **higher** the directivity, the **better**.

Isolation I

Isolation is the ratio of the **input power** (P_1^+) to the power out of the **isolation** port (P_4^-), expressed in decibels.

$$I(dB) = 10 \log_{10} \left[\frac{P_1^+}{P_4^-} \right] = -10 \log_{10} [|S_{41}|^2]$$

This value indicates how "isolated" the isolation port actually is. **Ideally** this is infinite (i.e., $P_4^- = 0$), so the **higher** the isolation, the better.

Note that isolation, directivity, and coupling are **not** independent values! **You** should be able to quickly show that:

$$I(dB) = C(dB) + D(dB)$$

Mainline Loss ML

The **mainline loss** is the ratio of the **input** power (P_1^+) to the power out of the **through** port (P_2^-), expressed in decibels.

$$ML(dB) = 10 \log_{10} \left[\frac{P_1^+}{P_2^-} \right] = -10 \log_{10} [|S_{21}|^2]$$

It indicates how much power the signal **loses** as it travels from the input to the through port.

Coupling Loss CL

The **coupling loss** indicates the **portion** of the mainline loss that is due to coupling some of the input power into the coupling port.

$$CL(dB) = 10 \log_{10} \left[\frac{P_1^+}{P_1^+ - P_3^-} \right] = -10 \log_{10} [1 - |j_c|^2]$$

Conservation of energy makes this loss is **unavoidable**. Note this value can be **very small**, for example:

The coupling loss of a **10dB** coupler is **0.44 dB**

The coupling loss of a **20dB** coupler is **0.044 dB**

The coupling loss of a **30dB** coupler is **0.0044 dB**

Insertion Loss IL

Q: *But wait, shouldn't $P_1^+ - P_3^- = P_2^-$, meaning the coupling loss and the mainline loss will be the **same exact value**?*

A: **Ideally** this would be true.

But, the reality is that couplers are **not perfectly lossless**, so there will additionally be loss due to **absorbed** energy (i.e., heat). This loss is called **insertion loss** and is simply the **difference** between the mainline loss and coupling loss:

$$IL(dB) = ML(dB) - CL(dB)$$

The insertion loss thus indicates the portion of the mainline loss that is **not** due to coupling some input power to the coupling port. This insertion loss is avoidable, and thus the **smaller** the insertion loss, the better.

For couplers with **very small coupling coefficients** (e.g., $C(dB) > 20$) the coupling loss is so small that the mainline loss

is almost entirely due to insertion loss (i.e., $ML = IL$)—often then, the two terms are used **interchangeably**.



From: paginas.fe.up.pt/~hmiranda/etele/microstrip/