

```
In[*]:= Get[FileNameJoin[{NotebookDirectory[], "EbookUtilities.wl"}]];
EbookUtilitiesPalette[];
```

```
In[*]:= Module[{nb = EvaluationNotebook[], size = 18, base, newSD},
  base = Cell[StyleData[StyleDefinitions → "Default.nb"]];
  newSD = Notebook[{base, Cell[StyleData["ItemNumbered"], FontSize → size]
    (*Add bullets too,if desired:Cell[StyleData["Item"],FontSize→size]*)},
  Visible → False, Saveable → False];
  SetOptions[nb, StyleDefinitions → newSD];]
```

```
In[*]:= ClearAll["Global`*"]
```

## EECS 361 Concept Question #11

1. Given  $x(t) = \text{rect}(\frac{t}{2}) - 0.5\text{tri}(t)$  find the Fourier transform of  $x(t)$ ,  $X(\omega)$ .

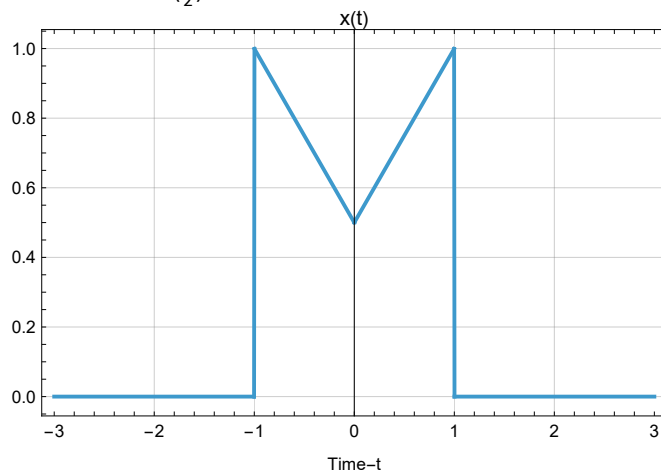

```
In[ ]:= x[t_] = (UnitBox[t/2] - 0.5 * UnitTriangle[t]);
Plot[x[t], {t, -3, 3}, ExclusionsStyle -> Automatic, GridLines -> Automatic,
PlotLabel -> "x(t)", Frame -> True, FrameLabel -> {"Time-t", ""}]
```

Out[ ]=

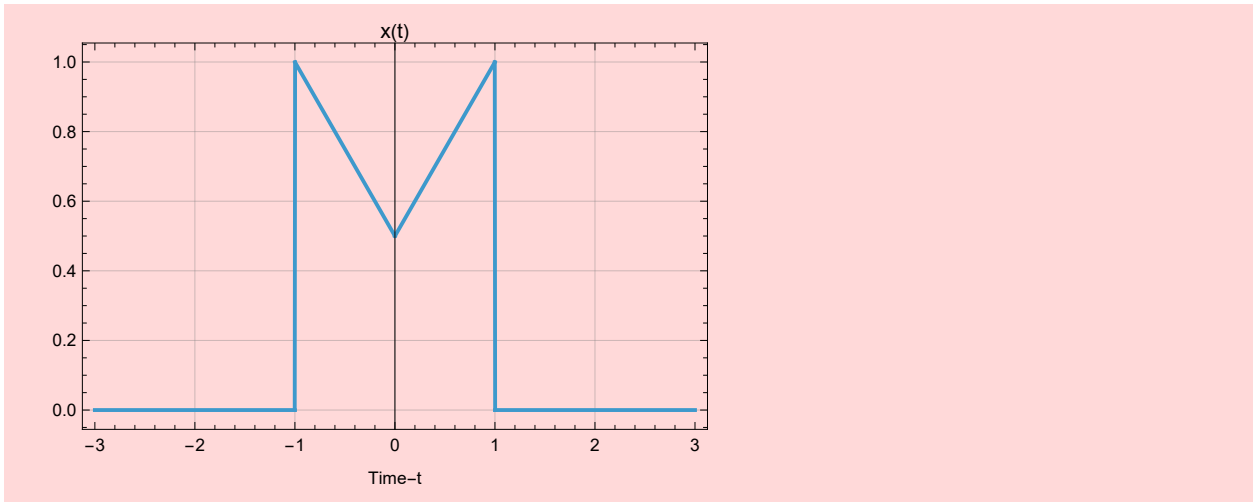

```
In[ ]:= X[ω_] = FourierTransform[x[t], t, ω, FourierParameters -> {1, -1}]
```

Out[ ]=

$$-0.5 \operatorname{Sinc}\left[\frac{\omega}{2}\right]^2 + 2 \operatorname{Sinc}[\omega]$$

```
In[6]:= Get[FileNameJoin[{NotebookDirectory[], "EbookUtilities.wl"}]];
EbookUtilitiesPalette[];
```

EECS 361  
Concept Question #12

1. Given  $x(t) = \text{rect}\left(\frac{t}{0.25}\right) \cos(200t)$  find the Fourier transform of  $x(t)$ ,  $X(\omega)$ .

Sketch  $X(\omega)$  on the grid below.

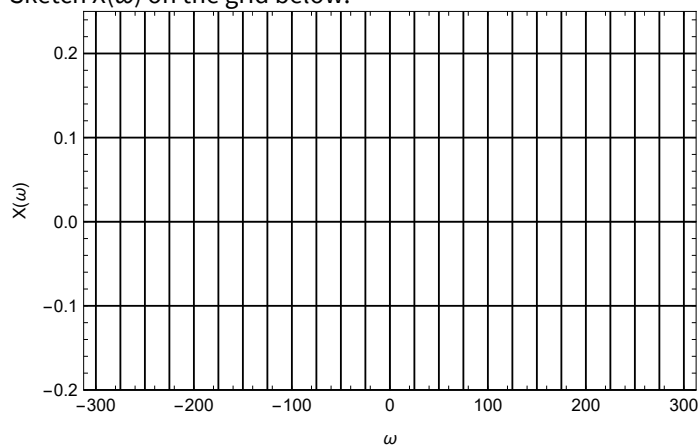

```
In[1]:= x[t_] = UnitBox[ $\frac{t}{0.25}$ ] * Cos[200 * t];
X[omega_] = FourierTransform[x[t], t, omega, FourierParameters -> {1, -1}]
```

```
Out[2]= 0.125 sinc(25. - 0.125 omega) + 0.125 sinc(0.125 omega + 25.)
```

```
In[5]:= Plot[X[ $\omega$ ], { $\omega$ , -300, 300}, PlotRange  $\rightarrow$  All, GridLines  $\rightarrow$  Automatic]
```

Out[5]=

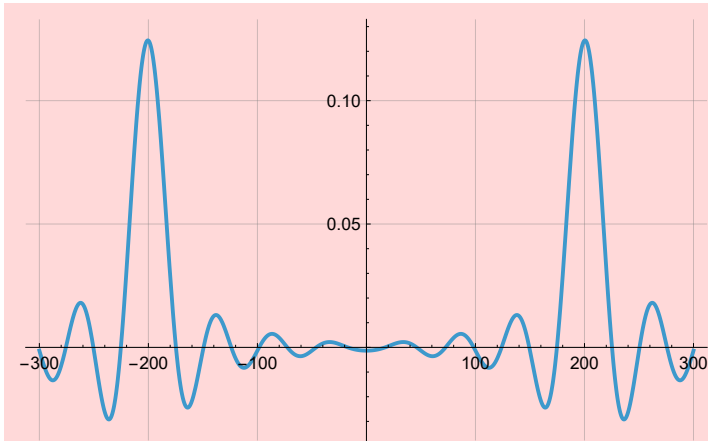

```
In[*]:= Get[FileNameJoin[{NotebookDirectory[], "EbookUtilities.wl"}]];
EbookUtilitiesPalette[];
```

```
In[*]:= Module[{nb = EvaluationNotebook[], size = 18, base, newSD},
  base = Cell[StyleData[StyleDefinitions → "Default.nb"]];
  newSD = Notebook[{base, Cell[StyleData["ItemNumbered"], FontSize → size]
    (*Add bullets too, if desired: Cell[StyleData["Item"], FontSize → size] *)},
    Visible → False, Saveable → False];
  SetOptions[nb, StyleDefinitions → newSD];]
```

```
In[*]:= ClearAll["Global`*"]
```

## EECS 361 Concept Question #13

1. Given  $y(t) = \text{rect}\left(\frac{t-0.05}{0.25}\right)$  find the Fourier transform of  $y(t)$ ,  $Y(\omega)$ .
2. Given  $x(t) = \text{rect}\left(\frac{t}{0.25}\right) \cos(200t)$  find the Fourier transform of  $x(t)$ ,  $X(\omega)$ .

Sketch  $X(\omega)$  on the grid below.

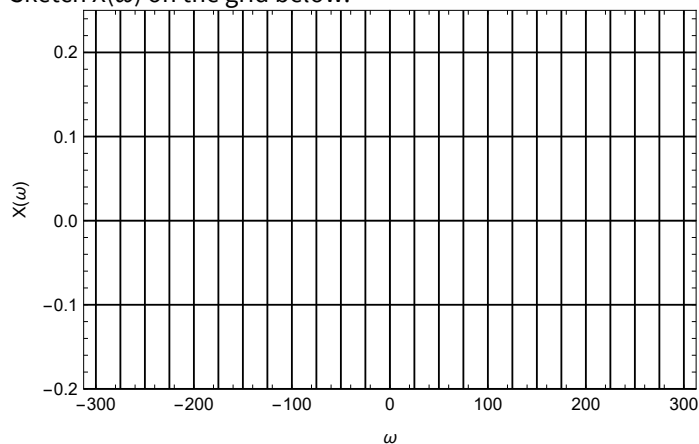

```

In[ ]:= x[t_] = UnitBox[ $\frac{t}{0.25}$ ] * Cos[200 t];
X[ $\omega$ _] = FourierTransform[x[t], t,  $\omega$ , FourierParameters -> {1, -1}];
Plot[X[ $\omega$ ], { $\omega$ , -300, 300}, PlotRange -> All, Frame -> True,
  FrameLabel -> {" $\omega$ ", "X( $\omega$ )"}, GridLines -> {Range[-300, 300, 25], Range[-.2, .5, 0.1]}]

Plot[X[ $\omega$ ], { $\omega$ , -300, 300}, PlotRange -> {-0.2, .25}, Frame -> True,
  FrameLabel -> {" $\omega$ ", "X( $\omega$ )"}, GridLines -> {Range[-300, 300, 25], Range[-.2, .25, 0.1]},
  PlotStyle -> None, GridLinesStyle -> Directive[Black, Thickness[0.003]]]

```

Out[ ]:=

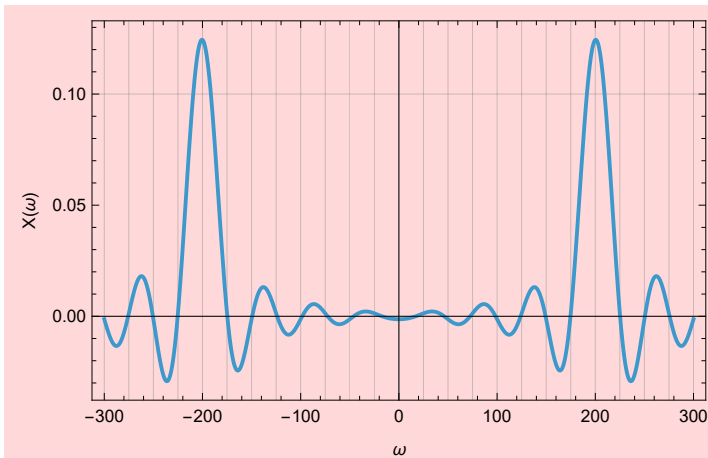

Out[ ]:=

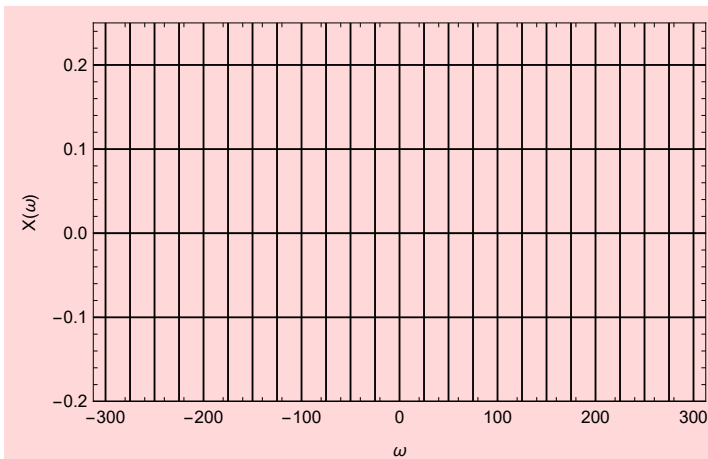

```

In[ ]:= y[t_] = UnitBox[ $\frac{t - 0.05}{0.25}$ ];
Y[ $\omega$ _] = FourierTransform[y[t], t,  $\omega$ , FourierParameters -> {1, -1}]

```

Out[ ]:=

$$\frac{2 \cdot e^{(0. - 0.05 i) \omega} \text{Sin}[0.125 \omega]}{\omega}$$

Out[\*]=

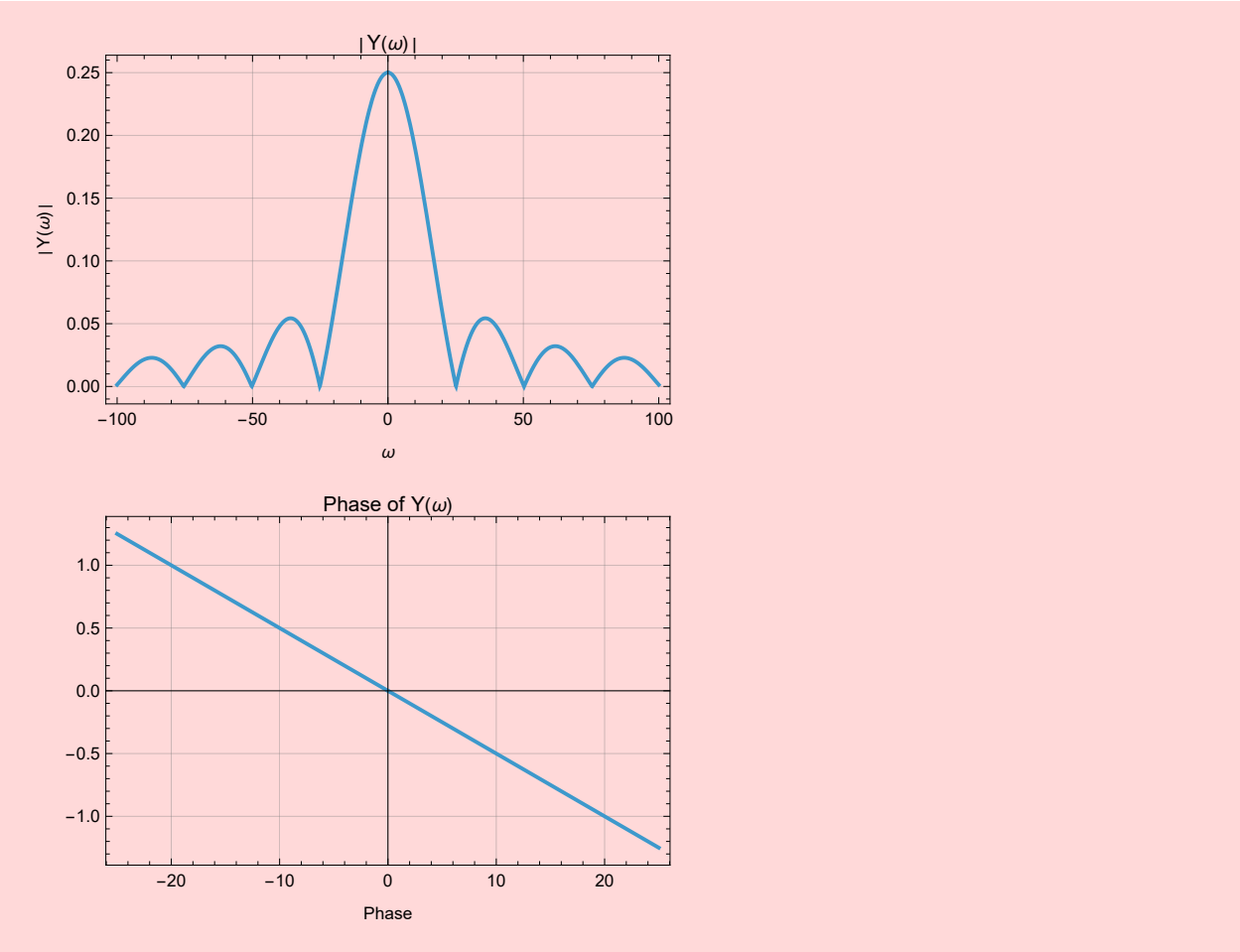

```
In[*]:= Get[FileNameJoin[{NotebookDirectory[], "EbookUtilities.wl"}]];
EbookUtilitiesPalette[];
```

```
In[*]:= Module[{nb = EvaluationNotebook[], size = 18, base, newSD},
  base = Cell[StyleData[StyleDefinitions -> "Default.nb"]];
  newSD = Notebook[{base, Cell[StyleData["ItemNumbered"], FontSize -> size]
    (*Add bullets too,if desired:Cell[StyleData["Item"],FontSize->size]*)},
  Visible -> False, Saveable -> False];
  SetOptions[nb, StyleDefinitions -> newSD];]
```

```
In[*]:= ClearAll["Global`*"]
```

EECS 361  
Concept Question #14

1. Given a frequency response,  $H(\omega)$ , shown below; the input to the system is  $x(t) = \frac{1}{5} + \frac{1}{5} \cos(0.5t) + \frac{1}{4} \cos(t) + \frac{1}{10} \cos(3t)$  find the output signal  $y(t)$ .

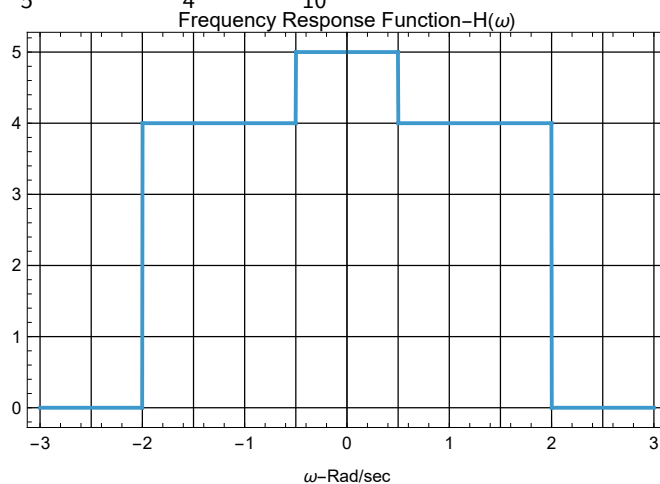

2. Find the impulse for this system.

```

In[ ]:= H[w_] = 1 * UnitBox[w] + 4 * UnitBox[ $\frac{w}{4}$ ];
Plot[H[w], {w, -3, 3}, ExclusionsStyle -> Automatic,
PlotLabel -> "Frequency Response Function-H( $\omega$ )",
GridLines -> {Range[-3, 3, 0.5], Range[0, 12, 1]}, Frame -> True,
FrameLabel -> {" $\omega$ -Rad/sec", ""}, GridLinesStyle -> Directive[Black, Thickness[0.002]]]

```

Out[ ]:=

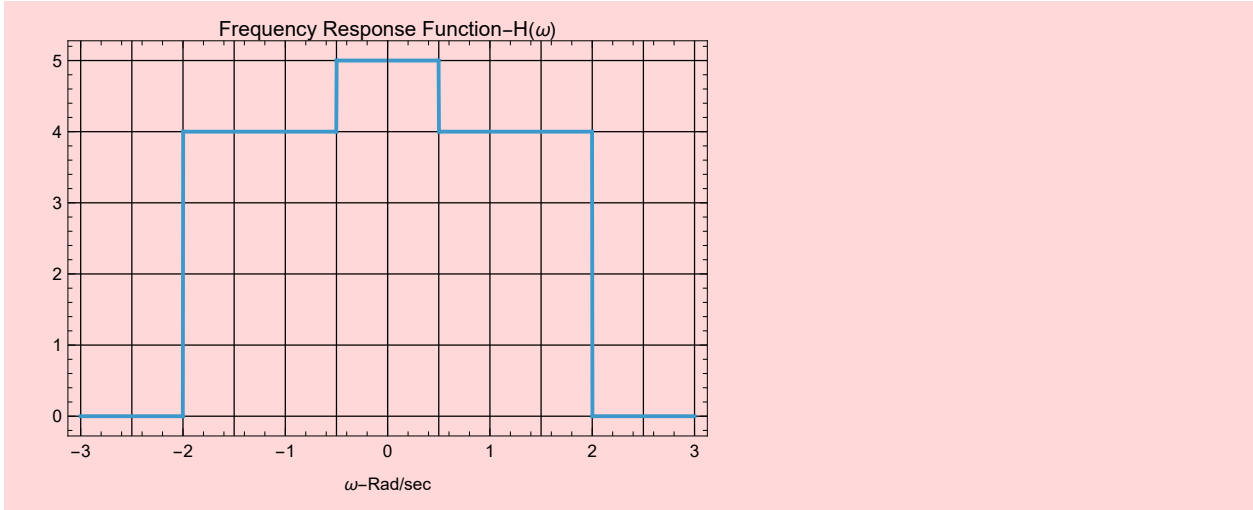

```

0.2 * H[0]
0.2 * H[.5]
0.25 * H[1]
0.10 * H[3]

```

Out[ ]:=

```
1.
```

Out[ ]:=

```
1.
```

Out[ ]:=

```
1.
```

Out[ ]:=

```
0.
```

```
1+1cos(0.5t)+1cos(t)+0cos(3t)
```

```
In[*]:= h[t_] = InverseFourierTransform[H[ω], ω, t, FourierParameters → {1, -1}]
```

```
Out[*]=
```

$$\frac{\text{Sinc}\left[\frac{t}{2}\right] + 16 \text{Sinc}[2t]}{2\pi}$$

```
In[*]:= H1[w_] = UnitBox[w]
InverseFourierTransform[H1[ω], ω, t, FourierParameters → {1, -1}]
```

```
Out[*]=
```

$$\text{UnitBox}[w]$$

```
Out[*]=
```

$$\frac{\text{Sinc}\left[\frac{t}{2}\right]}{2\pi}$$

```
In[*]:= H2[w_] = 4 * UnitBox[w / 4]
InverseFourierTransform[H2[ω], ω, t, FourierParameters → {1, -1}]
```

```
Out[*]=
```

$$4 \text{UnitBox}\left[\frac{w}{4}\right]$$

```
Out[*]=
```

$$\frac{8 \text{Sinc}[2t]}{\pi}$$

```
In[*]:= Get[FileNameJoin[{NotebookDirectory[], "EbookUtilities.wl"}]];
EbookUtilitiesPalette[];
```

```
In[*]:= Module[{nb = EvaluationNotebook[], size = 18, base, newSD},
  base = Cell[StyleData[StyleDefinitions -> "Default.nb"]];
  newSD = Notebook[{base, Cell[StyleData["ItemNumbered"], FontSize -> size]
    (*Add bullets too,if desired:Cell[StyleData["Item"],FontSize->size]*)},
  Visible -> False, Saveable -> False];
  SetOptions[nb, StyleDefinitions -> newSD];]
```

```
In[*]:= ClearAll["Global`*"]
```

## EECS 361

### Concept Question #15

1. Given a signal  $x(t) = \frac{\text{Sinc}\left[\frac{t}{2}\right]}{2\pi} + \frac{8 \text{Sinc}[2t]}{\pi}$ , find the bandwidth of  $x(t)$  in Hz.
2. Find the Nyquist rate (in samples/sec) for sampling  $x(t)$ .
3. Set sample rate at 1.5 the Nyquist rate and sketch the spectrum of the sampled signal.
4. For a sample rate at 1.5 the Nyquist rate how is  $x(t)$  recovered from the sampled signal,  $x_s(t)$ .

1.  $B = 2 \text{ rad/sec} = B_{\text{Hz}} = \frac{1}{\pi} \approx .318 \text{ Hz}$
2.  $f_{\text{Nyquist}} = \frac{2}{\pi} \text{ samples/sec}$
- 3.
4. LPF

```
In[ ]:= H1[w_] = 1 * UnitBox[w] + 4 * UnitBox[ $\frac{w}{4}$ ];  
Plot[H1[w], {w, -3, 3}, ExclusionsStyle -> Automatic,  
PlotLabel -> "Frequency Response Function-H( $\omega$ )",  
GridLines -> {Range[-3, 3, 0.5], Range[0, 12, 1]}, Frame -> True,  
FrameLabel -> {" $\omega$ -Rad/sec", ""}, GridLinesStyle -> Directive[Black, Thickness[0.002]]]
```

Out[ ]:=

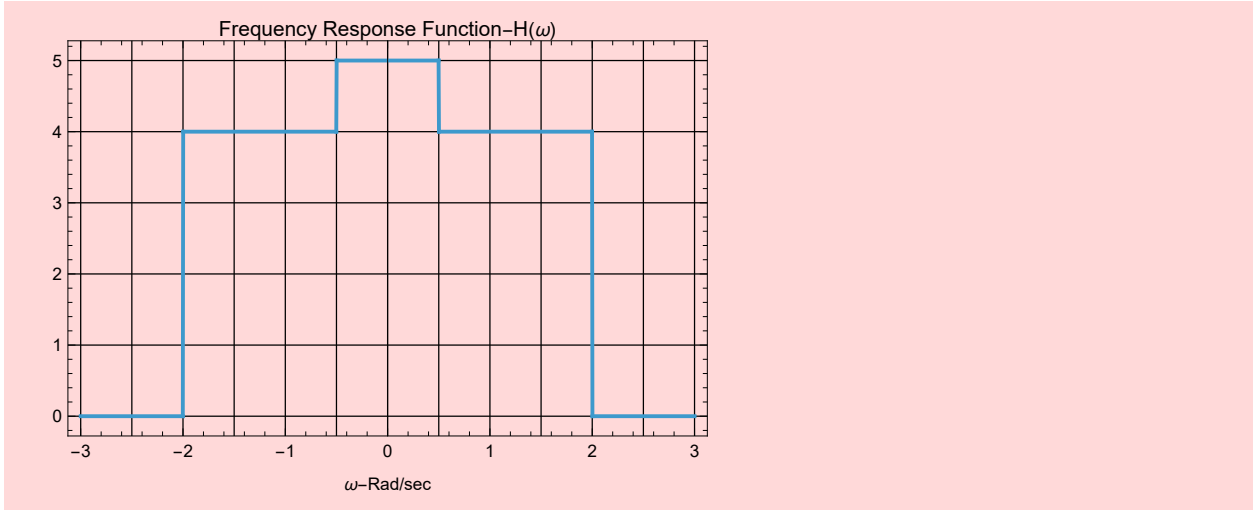

$$0.5 \text{ rad/sec} = 0.79 \text{ Hz} \quad \text{and} \quad B = 2 \text{ rad/sec} = B_{\text{Hz}} = \frac{1}{\pi} \approx 0.318 \text{ Hz}$$

```

In[*]:= H[f_] = 1 * UnitBox[ $\frac{f}{2}$ ] + 4 * UnitBox[ $\frac{f}{1}$ ];

Plot[H[f], {f, -1, 1}, ExclusionsStyle -> Automatic,
  PlotLabel -> "Frequency Response Function-H( $\omega$ )",
  GridLines -> {Range[-1, 1, 0.5], Range[0, 12, 1]}, Frame -> True,
  FrameLabel -> {" $\omega$ -Rad/sec", ""}, GridLinesStyle -> Directive[Black, Thickness[0.002]]];

fs =  $\frac{2}{\pi}$  * 1.5;

Plot[ $\sum_{k=-3}^3 H[f - k * fs]$ , {f, -3, 3}, ExclusionsStyle -> Automatic,
  PlotLabel -> "Xs(f)", GridLines -> {Range[-3, 3, 0.5], Range[0, 12, 1]}, Frame -> True,
  FrameLabel -> {"f", ""}, GridLinesStyle -> Directive[Black, Thickness[0.002]]]

```

Out[\*]=

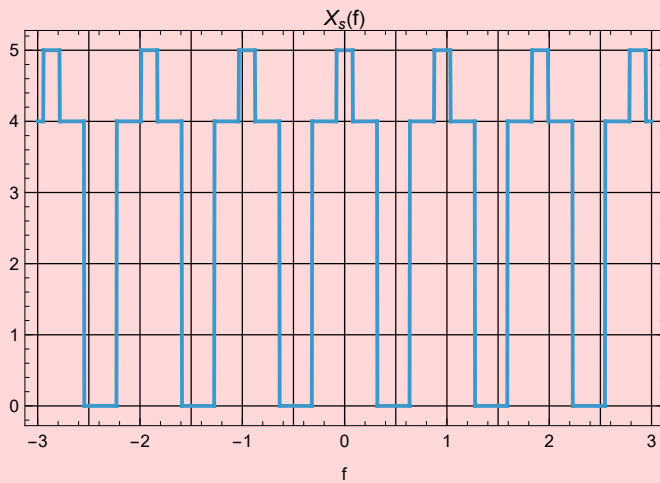

```
In[*]:= Get[FileNameJoin[{NotebookDirectory[], "EbookUtilities.wl"}]];
EbookUtilitiesPalette[];
```

```
In[*]:= Module[{nb = EvaluationNotebook[], size = 18, base, newSD},
  base = Cell[StyleData[StyleDefinitions → "Default.nb"]];
  newSD = Notebook[{base, Cell[StyleData["ItemNumbered"], FontSize → size]
    (*Add bullets too, if desired: Cell[StyleData["Item"], FontSize → size] *)},
  Visible → False, Saveable → False];
  SetOptions[nb, StyleDefinitions → newSD];]
```

```
In[*]:= ClearAll["Global`*"]
```

## EECS 361

### Concept Question #16

1. Given  $y[n] = x[n+2] + 2x[n+1] + 3x[n] + 2x[n-1] + x[n-1]$  Find the impulse response,  $h[n]$ .
2. Is this system BIBO stable?
3. Is the system causal?

1.  $h[n] = \delta[n+2] + 2\delta[n+1] + 3\delta[n] + 2\delta[n-1] + \delta[n-1]$
2. Yes
3. No

```
In[*]:= Get[FileNameJoin[{NotebookDirectory[], "EbookUtilities.wl"}]];
EbookUtilitiesPalette[];
```

```
In[*]:= Module[{nb = EvaluationNotebook[], size = 18, base, newSD},
  base = Cell[StyleData[StyleDefinitions -> "Default.nb"]];
  newSD = Notebook[{base, Cell[StyleData["ItemNumbered"], FontSize -> size]
    (*Add bullets too,if desired:Cell[StyleData["Item"],FontSize->size]*)},
  Visible -> False, Saveable -> False];
  SetOptions[nb, StyleDefinitions -> newSD];]
```

```
In[*]:= ClearAll["Global`*"]
```

## EECS 361

### Concept Question #17

1. Given  $H(z) = \frac{z^2}{z^2 + 0.81}$  place the poles and zeros on the z-plane below.

Hint:  $z^2 + 0.81 = (z - 0.9 e^{j\frac{\pi}{2}})(z - 0.9 e^{-j\frac{\pi}{2}})$

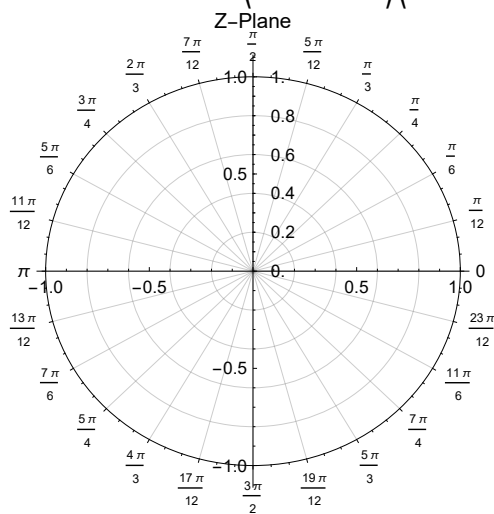

2. Is this system BIBO stable?
3. Is this system a,
  - i. LPF
  - ii. BPF
  - iii. BRF
  - iv. HPF
 Answer: \_\_\_\_
4. What is the corresponding difference equation, i.e., implementation.
5. Draw a system block diagram.

1.

In[ ]:= Simplify [ComplexExpand [(z - .9 \* Exp[I \*  $\frac{\pi}{2}$ ]) \* (z - .9 \* Exp[-I \*  $\frac{\pi}{2}$ ])] ]

Out[ ]:= (0.81 + 0. i) + z<sup>2</sup>

In[ ]:= Roots [z<sup>2</sup> + 0.81 == 0, z]

Out[ ]:= z == 0. + 0.9 i || z == 0. - 0.9 i

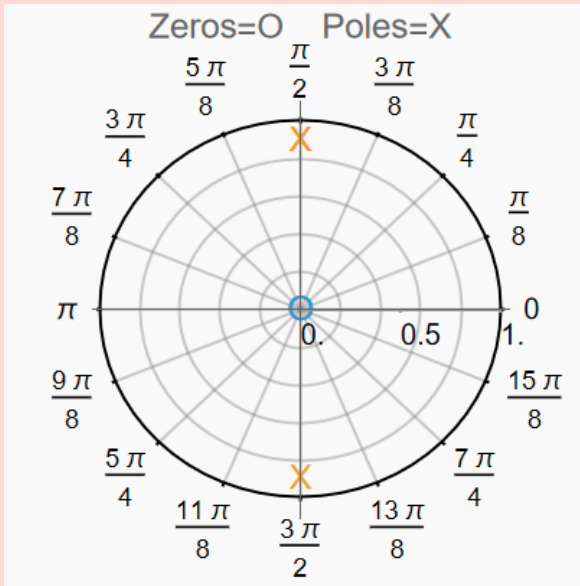

2. YES

3. BPF

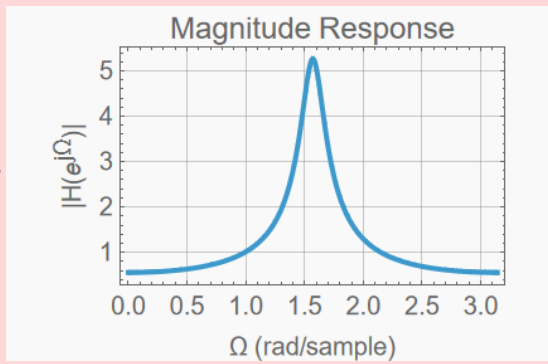

4.  $y[n]=x[n]-0.81y[n-2]$

5.

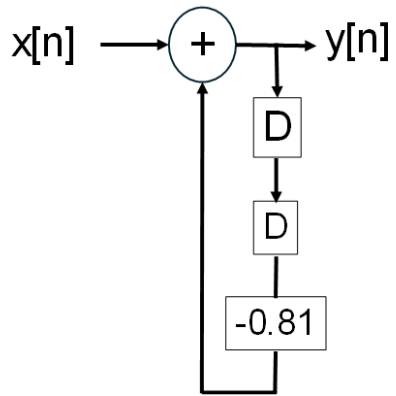

```
In[*]:= Get[FileNameJoin[{NotebookDirectory[], "EbookUtilities.wl"}]];
EbookUtilitiesPalette[];
```

```
In[*]:= Module[{nb = EvaluationNotebook[], size = 18, base, newSD},
  base = Cell[StyleData[StyleDefinitions -> "Default.nb"]];
  newSD = Notebook[{base, Cell[StyleData["ItemNumbered"], FontSize -> size]
    (*Add bullets too,if desired:Cell[StyleData["Item"],FontSize->size]*)},
  Visible -> False, Saveable -> False];
  SetOptions[nb, StyleDefinitions -> newSD];]
```

```
In[*]:= ClearAll["Global`*"]
```

EECS 361  
Concept Question #18

1. Given  $h[n] = \{0, 1, 1\}$ , find  $H(z)$  as a ratio of two polynomials with positive exponents.
2. Given  $x[n] = \{1, 2, 3\}$ , find the system output  $y[n] = x[n]*h[n]$
3. Given  $H(z) = \frac{2z}{z-0.5} + \frac{0.9z}{(z-0.9)^2}$  Find  $h[n]$ . Hint: Use z-Transform table.

1.  $H(z) = \frac{z+1}{z^2}$

2.

```
In[*]:= ListConvolve[{0, 1, 1}, {1, 2, 3}, {1, -1}, 0]
```

```
Out[*]=
```

{0, 1, 3, 5, 3}

3.	4	$a^n u[n]$	$\iff$	$\frac{z}{z-a}$
	4b	$na^n u[n]$	$\iff$	$\frac{az}{(z-a)^2}$

$h[n] = 2(0.5)^n u[n] + n(0.9)^n u[n]$

```
In[*]:= Get[FileNameJoin[{NotebookDirectory[], "EbookUtilities.wl"}]];
EbookUtilitiesPalette[];
```

```
In[*]:= Module[{nb = EvaluationNotebook[], size = 18, base, newSD},
  base = Cell[StyleData[StyleDefinitions → "Default.nb"]];
  newSD = Notebook[{base, Cell[StyleData["ItemNumbered"], FontSize → size]
    (*Add bullets too, if desired: Cell[StyleData["Item"], FontSize → size] *)},
  Visible → False, Saveable → False];
  SetOptions[nb, StyleDefinitions → newSD];]
```

```
In[*]:= ClearAll["Global`*"]
```

## EECS 361

### Concept Question #20

1. A discrete time system is given by  $y[n] = x[n] + 3x[n-1] + x[n-2]$ .
  - a. Find  $H(z)$  as a ratio of polynomials in  $z$  with positive exponents.
  - b. An analog signal  $x(t) = \cos(2\pi 1000t)$  is sampled at a rate of 2000 samples/sec to create an input signal. What is the system output,  $y[n]$ ?
  - c. A DC gain of 1 is required, modify the difference equation accordingly.

a.

```
In[*]:= H[z_] = 
$$\frac{1 + 3z + z^2}{z^2}$$

```

Out[\*]=

$$\frac{1 + 3z + z^2}{z^2}$$

```
In[*]:= Plot[Abs[H[Exp[I * Ω]]], {Ω, 0, π}, GridLines -> Automatic]
```

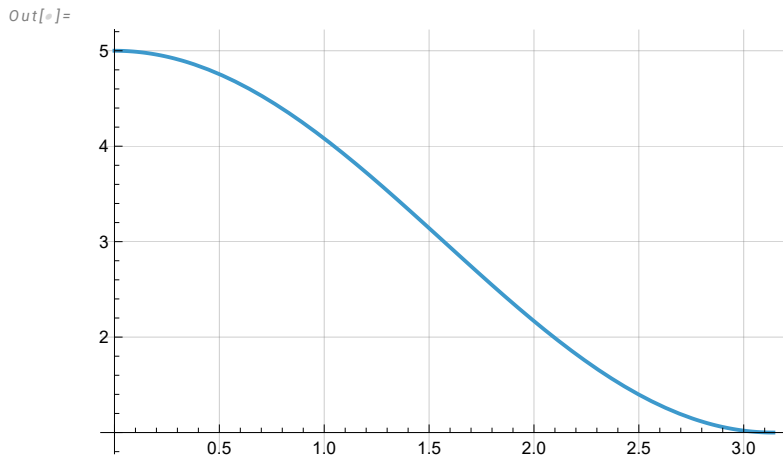

```
In[*]:= Roots[1. + 3 z + z^2 == 0, z]
```

```
Out[*]= z == -2.61803 | | z == -0.381966
```

b.

```
In[*]:= 
$$\frac{2 * \pi * 1000}{2000}$$

```

```
Out[*]= π
```

$$x[n] = \cos(\pi n)$$

```
In[*]:= H[Exp[I * π]]
```

```
Out[*]= -1
```

$$y[n] = -\cos(\pi n)$$

c.  $0.2x[n] + 0.6x[n-1] + 0.2x[n-2]$ .

```
In[*]:= H[Exp[I * 0]]
```

```
Out[*]= 5
```

```
In[*]:= Hn[z_] = 
$$\frac{0.2 + 0.6 z + 0.2 z^2}{z^2}$$

```

```
Out[*]=
```

$$\frac{0.2 + 0.6 z + 0.2 z^2}{z^2}$$

```
In[*]:= Hn[Exp[I * 0]]
```

```
Out[*]=
```

1.

```
In[*]:= Get[FileNameJoin[{NotebookDirectory[], "EbookUtilities.wl"}]];
EbookUtilitiesPalette[];
```

```
In[*]:= Module[{nb = EvaluationNotebook[], size = 18, base, newSD},
  base = Cell[StyleData[StyleDefinitions -> "Default.nb"]];
  newSD = Notebook[{base, Cell[StyleData["ItemNumbered"], FontSize -> size]
    (*Add bullets too,if desired:Cell[StyleData["Item"],FontSize->size]*)},
    Visible -> False, Saveable -> False];
  SetOptions[nb, StyleDefinitions -> newSD];]
```

```
In[*]:= ClearAll["Global`*"]
```

EECS 361  
Concept Question #19

1.  $H(z)$  has the pole/zero diagram given below.

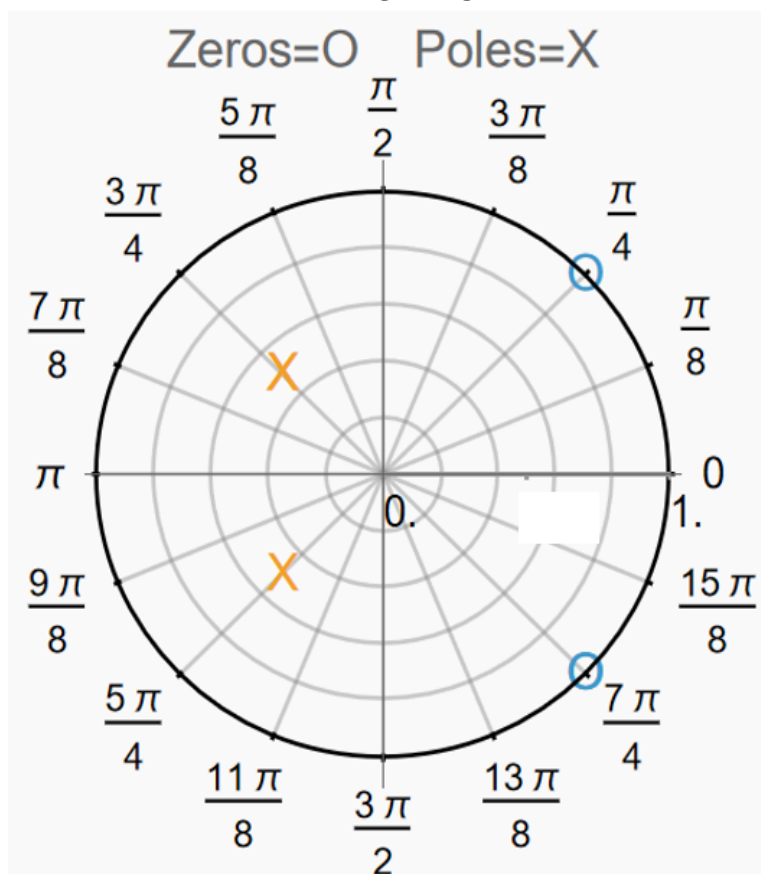

Is this system a,  
i. LPF ii. BPF iii. BRF iv. HPF Answer: \_\_\_\_

- A signal  $x(t) = \cos(2\pi 1000t)$  is sampled at a rate of 8000 samples/sec to create  $x[n]$ . The discrete time signal  $x[n]$  is input to the filter given above. What is the system output.
- What is the DC gain of this filter.

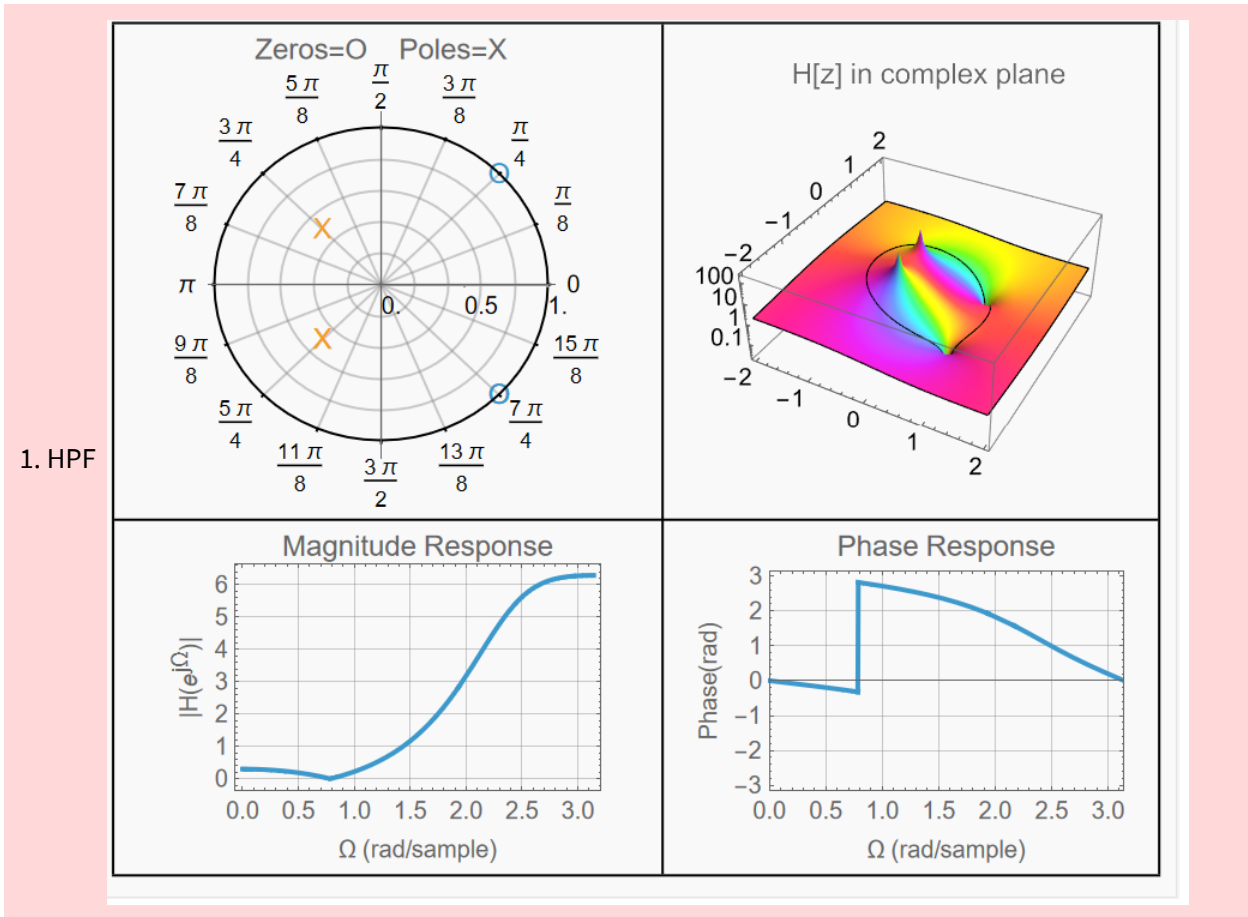

2.

```
In[*]:=
f1 = 1000;
fs = 8000;
digf =  $\frac{2 * \pi * f1}{fs}$ 
```

Out[\*]=

$$\frac{\pi}{4}$$

$$H\left(e^{j\frac{\pi}{4}}\right) = 0 \text{ output } y[n] = 0$$

3.

$$\text{In[*]:= } H[z_] = \frac{(z - \text{Exp}[I * \frac{\pi}{4}]) (z - \text{Exp}[-I * \frac{\pi}{4}])}{(z - 0.5 * \text{Exp}[I * \frac{3\pi}{4}]) (z - 0.5 * \text{Exp}[-I * \frac{3\pi}{4}])}$$

Out[\*]=

$$\frac{\left(-e^{-\frac{i\pi}{4}} + z\right) \left(-e^{\frac{i\pi}{4}} + z\right)}{\left((0.353553 - 0.353553 i) + z\right) \left((0.353553 + 0.353553 i) + z\right)}$$

$$\text{In[*]:= } H\left[\text{Exp}\left[I * \frac{\pi}{4}\right]\right]$$

Out[\*]=

$$0. + 0. i$$

$$\text{In[*]:= } \text{Abs}[H[\text{Exp}[I * 0.]]]$$

Out[\*]=

$$0.299312$$

In[\*]:=

$$H1[z_] = \frac{z^2 - \sqrt{2} z + 1}{z^2 + \frac{\sqrt{2}}{2} z + \frac{1}{4}};$$

$$\text{Abs}[H1[\text{Exp}[I * 0.]]]$$

Out[\*]=

$$0.299312$$

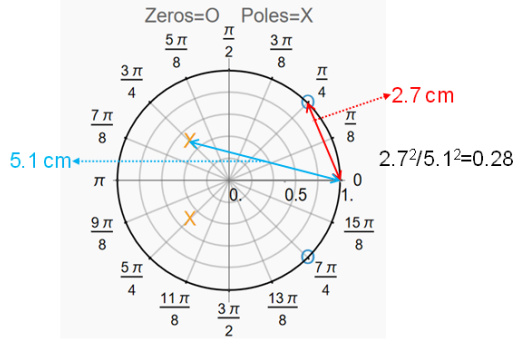

Find  $|H(e^{j\Omega})|$      $\Omega_1 = 0$                        $\Omega_3 = \frac{\pi}{4}$   
 $|H(e^{j0})|$                        $|H(e^{j\frac{\pi}{4}})| = 0$   
 $= \sim 0.28$  (Measured)  
 $= 0.299$  (true value)                      This a HPF

$$H(z) = \frac{(z - e^{j\frac{\pi}{4}})(z - e^{-j\frac{\pi}{4}})}{(z - 0.5e^{j\frac{3\pi}{4}})(z - 0.5e^{-j\frac{3\pi}{4}})} = \frac{z^2 - \sqrt{2}z + 1}{z^2 + \frac{\sqrt{2}}{2}z + \frac{1}{4}}$$

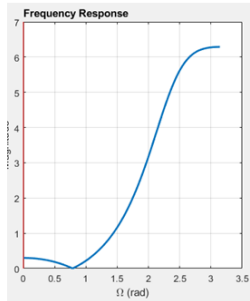

Difference Equation

$$y(n) = 1 \cdot x(n - 2) - 1.41478 x(n - 1) + x(n) - 0.25 y(n - 2) - 0.706969 y(n - 1)$$

```
In[*]:= Get[FileNameJoin[{NotebookDirectory[], "EbookUtilities.wl"}]];
EbookUtilitiesPalette[];
```

```
In[*]:= Module[{nb = EvaluationNotebook[], size = 18, base, newSD},
  base = Cell[StyleData[StyleDefinitions → "Default.nb"]];
  newSD = Notebook[{base, Cell[StyleData["ItemNumbered"], FontSize → size]
    (*Add bullets too,if desired:Cell[StyleData["Item"],FontSize→size]*)},
  Visible → False, Saveable → False];
  SetOptions[nb, StyleDefinitions → newSD];]
```

```
In[*]:= ClearAll["Global`*"]
```

EECS 361  
Concept Question #20

1. A discrete time system is given by  $y[n] = x[n] + 3x[n-1] + x[n-2]$ .
  - a. Find  $H(z)$  as a ratio of polynomials in  $z$  with positive exponents.
  - b. An analog signal  $x(t) = \cos(2\pi 1000t)$  is sampled at a rate of 2000 samples/sec to create an input signal. What is the system output,  $y[n]$ ?
  - c. A DC gain of 1 is required, modify the difference equation accordingly.

a.

```
In[*]:= H[z_] = 
$$\frac{1 + 3z + z^2}{z^2}$$

```

Out[\*]=

$$\frac{1 + 3z + z^2}{z^2}$$

```
In[*]:= Plot[Abs[H[Exp[I * Ω]]], {Ω, 0, π}, GridLines → Automatic]
```

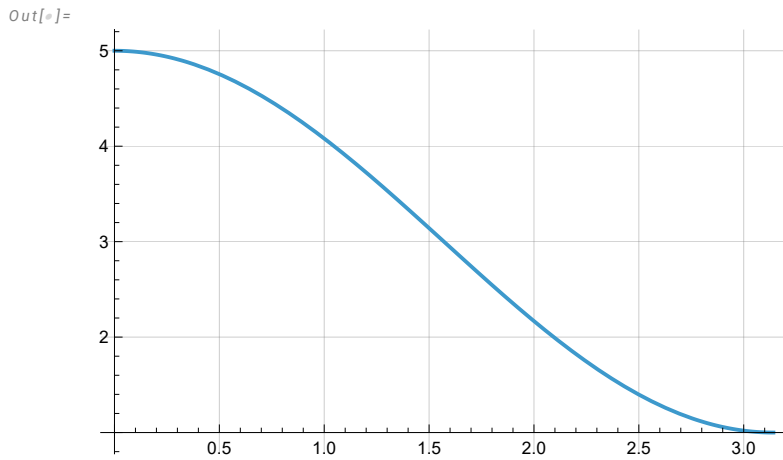

```
In[*]:= Roots[1. + 3 z + z^2 == 0, z]
```

```
Out[*]= z == -2.61803 | | z == -0.381966
```

b.

```
In[*]:= 
$$\frac{2 * \pi * 1000}{2000}$$

```

```
Out[*]= π
```

$$x[n] = \cos(\pi n)$$

```
In[*]:= H[Exp[I * π]]
```

```
Out[*]= -1
```

$$y[n] = -\cos(\pi n)$$

c.  $0.2x[n] + 0.6x[n-1] + 0.2x[n-2]$ .

```
In[*]:= H[Exp[I * 0]]
```

```
Out[*]= 5
```

```
In[*]:= Hn[z_] = 
$$\frac{0.2 + 0.6 z + 0.2 z^2}{z^2}$$

```

```
Out[*]=
```

$$\frac{0.2 + 0.6 z + 0.2 z^2}{z^2}$$

```
In[*]:= Hn[Exp[I * 0]]
```

```
Out[*]=
```

1.